

MICRON T 2487 50W Soldering Iron

It is one portable, temp-control and temp adjustable soldering iron. Ceramic heater, and three cores grounding wire ensures safety of soldering works.

Read this manual before set up or use this product, and save for future reference.

1. PARTS LIST & ASSEMBLY DIAGRAM

SA-50

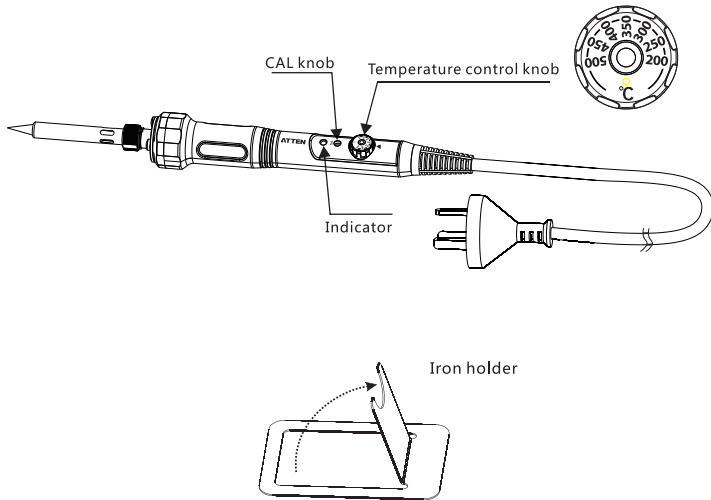

Please open it in the direction of arrow when using.

2. SEPCIFICATIONS

Power consumption	50W
Input voltage	100V/110V/120V 220V/230/240V(Optional)
Temperature range	200 ~ 500°C (392 ~ 932°F)
Temperature stability	±2°C (still air, no load)
Temperature accuracy	±10°C
Tip to ground impedance	< 2Ω
Tip to ground voltage	< 2mV
Temperature adjustment	Buttons
Heater	Four-core ceramic heater
length of handle	240mm Wire
weight	Around 186g

※ Specifications and design are subject to change without notice.

3. GENERAL SAFETY RULES

※ Please operate strictly as following rules for safety.

⚠ WARNING

The tip temperature reach 200-500°C when power is on. Please read all instructions. Failure to follow all instructions listed below may result in electric shock, fire, or serious injury:

- Do not touch the tip and metal surrounding.
- Do not use it near inflammable materials.
- Warn bystanders not to touch the tip.
- Please cut off the power after work finished.
- Do not change power wire personally or extend the wire.
- User should be trained technically before using.
- Keep children and bystanders away while operating a power tool.
- Have your power tool serviced by a qualified repair person using only identical replacement parts. This will ensure that the safety of the power tool is maintained.

※ Follow all instructions listed below, in case of accident happening or product damage.

⚠ CAUTION

- Do not use it to non-welding works.
- Do not hit the tip heavily for tin removing.
- Do not re-assemble this iron personally.
- Please only use identical replacement parts.
- Do not put it in the water.
- Please hold plug tightly when plug-out of power, do not pull the wire.
- Please operate this iron in a well-ventilated area because of smoking caused.
- Do not do other dangerous activity.

4. OPERATING INSTRUCTION

※ Steps

- 4.1. Make sure the input power before using.
- 4.2. Turn around control button, set temperature according to needs.
- 4.3. Plug the power wire into socket.
- 4.4. When the indicator lights, temperature is rising.
- 4.5. When power light glitters, the tip temperature reaches the pre-set.
- 4.6. Do soldering work normally.
 - Press the tip onto welding parts to heat up.
 - Add solder in welding parts and melt.
 - When solder spread to cover entire welding parts, remove the tip and solidify welding parts.

MICRON T 2487 50W Soldering Iron

Notice: Soldering can not be done if tip with oil or coating on the surface. Recommend to use solder containing rosin.

※ How to set the temperature

- ◇ Hold the handle firmly, turn the control knob. Set the arrow to the desired temperature indication.
- ◇ When turning the control knob, it is easy to always set the same position because there is click at each temperature indication. Temperature is also controlled in positions between clicks.

※ How to calibrate the temperature

- ◇ If more accurate temp is needed, please calibrate the temperature. When the tip temp reaches pre-set degree, using tip thermometer to measure the temp. And turn around CAL button, clockwise for heating, anti-clockwise for cooling, until tip displays same as thermometer.
- ◇ Temp needs to be calibrated when change temperature setting, change its tip and heater.
- ◇ The original temperature is $350 \pm 10^\circ\text{C}$.

5. MAINTENANCE AND SERVICES

⚠ WARNING

- Proper use and regular maintenance extends product life. The welding efficiency depends on the welding temperature, the quality and quantity of solder flux, regular maintenance based on usage.
- The tip is in high temp. Be careful when using. Maintenance must be done after power off and plug out.

Picture of tip head :

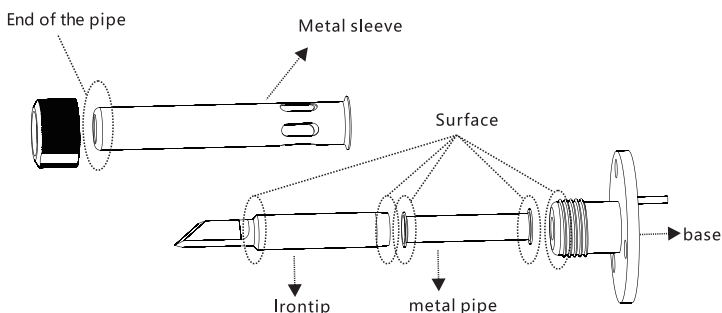

6. TROUBLE SHOOTING GUIDE

Trouble	Reason	Dealing way
The tip temperature is too low	The power cord is disconnected	Connect the power
	The Heater is broken	Replace the heater with a new one
Tip heats up intermittently	The cord assembly is broken	Replace the cord assembly
	Defective soldering when replacing the heater	Solder it again
Tip temp can not reach pre-setting temperature	Temperature is not calibrated	Calibrate temperature
	Tip is deteriorated	Correct the temperature after replacing the tip
Solder does not wet to the tip temperature	The presetting tip temperature is too high	Decrease the setting temperature
	Tip is oxidated	Change the tip
Electric potential between tip and grounding wire is too high	Defective cleaning the grounding line	Clean the grounding wire
	Enclosure nut is not tightened firmly	Tighten the enclosure nut again

7. REPLACABLE TIPS

- T 2433: 0.2mm Round
- T 2434: 0.8mm Chisel
- T 2435: 1.6mm Chisel
- T 2436: 3.2mm Chisel
- T 2472: 2mm Mini-wave