

Major Application(s): Security System

CE MH 26335

PHYSICAL SPECIFICATION

Nominal Voltage		12V
Nominal Capacity (20HR)		1.3AH
Dimensions	Length	97 ± 1mm (3.82 inches)
	Width	43 ± 1mm (1.69 inches)
	Container Height	52 ± 2mm (2.05 inches)
	Total Height	57 ± 2mm (2.24 inches)
Weight		Approx 0.57 kg (1.254 lbs)
Standard Terminal		F3-Fasten Tab No. 187A

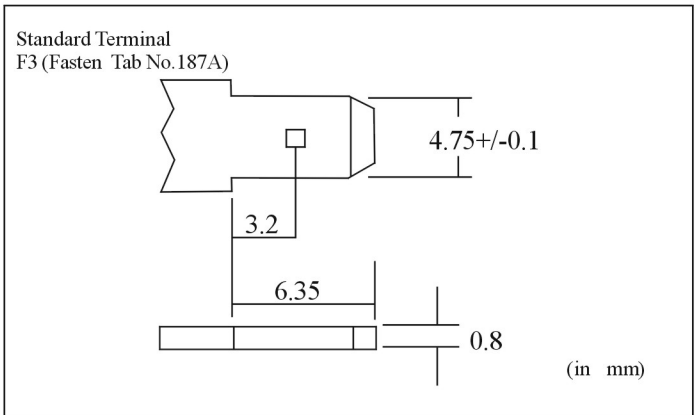
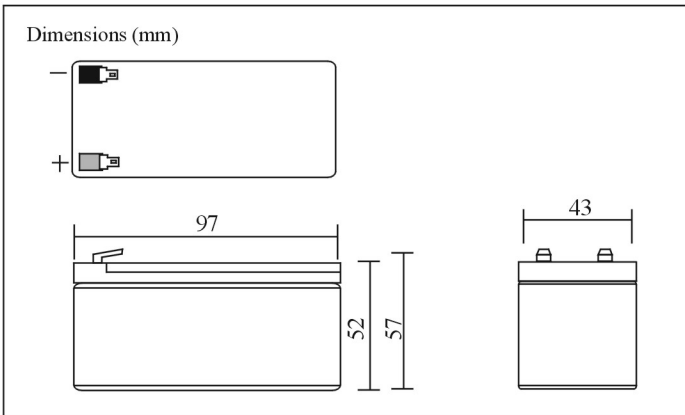

ELECTRICAL SPECIFICATION

Capacity	20 hour rate (0.065A)	1.3AH	It is recommended to use constant-voltage charge and recharge immediately after use	
	10 hour rate (0.11A)	1.1AH		
	5 hour rate (0.20A)	1.0AH		
	1 hour rate (0.78A)	0.78AH		
Capacity affected by Temperature	40°C (104°F)	105%	Constant-Voltage Charge	
	25°C (77°F)	100%		
	0°C (32°F)	85%		
Internal Resistance	Fully charged battery (25°C, 77°F) 75mΩ		Cycle	
				Initial Charging Current less than 0.39 A
			Standby	Voltage 14.4V~15V at 25°C (77°F)
				Voltage 13.5V~13.8V at 25°C (77°F)
				Temperature Coefficient -30mV/°C
				Temperature Coefficient -20mV/°C

