

# ALTRONICS Specification Sheet

Phone: 1300 797 007    Internet: [www.altronics.com.au](http://www.altronics.com.au)  
 Fax: 1300 789 777    Email: [info@altronics.com.au](mailto:info@altronics.com.au)  
 International Phone: +61 8 9428 2188

Manufactures please note, we recommend that a sample is obtained to confirm suitability. Specifications subject to change without notice.E&OE. © Altronic Distributors Pty. Ltd. ABN 84 177 396 871

Revision Date: 11/06/2010

Altronics Part Number	Description	Supplier Ordering Info
H 0393	Ritec® IP65 Sealed ABS Enclosures Hi-Top 125L x 85W x 85H mm	RP1155

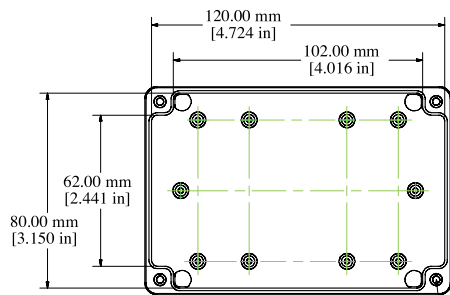
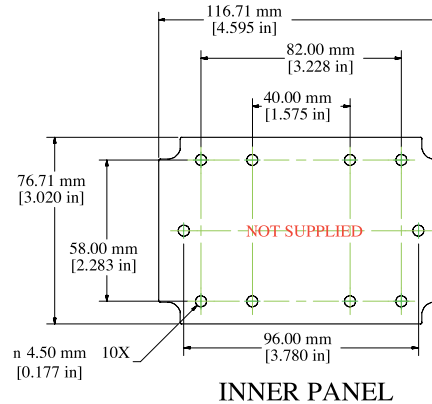
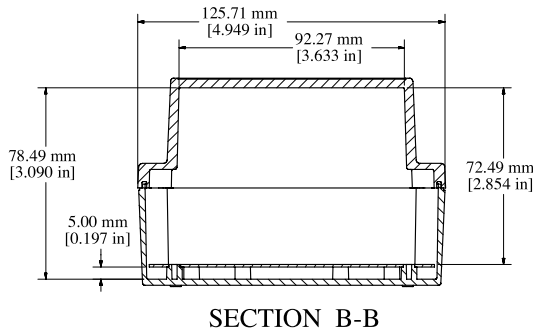
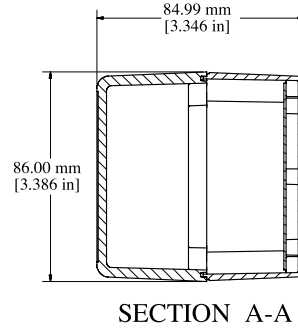
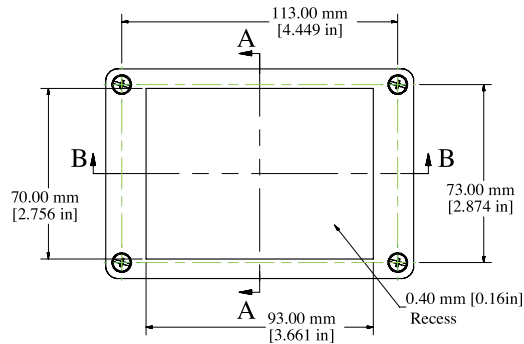

M3.5 Stainless Steel Lid Inserts  
Type 304 Stainles 4X

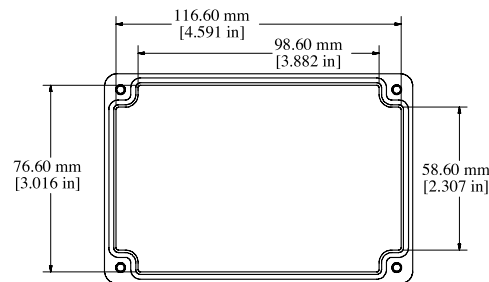

RP1155
Material: ABS (UL94-HB), Light Grey Color
Lid Screws: M3.5 x 10, 304 Stainless
Gasket: EDPM Cord.
Circuit Board Screws, 4 Supplied (M3 self tap)
Suggested Lid Screw Torque: 30 ozf-in (21 cN-m)

Measurements given in mm.