

# DATA LOGGER DMM

## User's Manual

\*\* The specification may be changed to improve the product quality without notifying the customers.

Ref # D6x0-112509-R0

# CONTENTS

CHAPTER	ITEM	Page
1.	INTRODUCTION	
	1-1. Main Features	
2.	SAFETY CONSIDERATIONS	
	2-1. Safety Information: Read First	
3.	EXPLANATION OF CONTROLS AND INDICATIONS	
	3-1. PANEL CONFIGURATION	
	3-2. LCD CONFIGURATION	
4.	GENERAL SPECIFICATIONS	
	4-1. DISPLAY	
	4-2. ENVIRONMENTAL	
	4-3. MAXIMUM INPUT & PROTECTION TYPE	
	4-4. POWER SUPPLY	
	4-5. MECHANICAL	
	4-6. ACCESSORY	
5.	ELECTRICAL SPECIFICATION	
	5-1. DC V	
	5-2. AC V	
	5-3. Resistance	
	5-4. Continuity	
	5-5. Diode Test	
	5-6. Capacitance	
	5-7. Frequency	
	5-8. Period	
	5-9. Duty cycle	
	5-10. Period	
	5-11. Duty cycle	
	5-12. Pulse Width	
	5-13. Temperature	
	5-14. DC A	
	5-15. AC A	
	5-16. AC + DC A	
6.	ELECTRICAL TESTS AND MEASUREMENTS	
	6-1. DC V	
	6-2. AC V	
	6-3. Resistance	
	6-4. Continuity	
	6-5. Diode Test	
	6-6. Continuity	



# 1. INTRODUCTION

This Meter is a handheld, battery-operated DMM-type Digital Multimeter [Data Logger] designed and tested according to IEC Publication 1010-1 (EN 61010-1:1993, Over voltage Category II & III), ...

## 1-1. Main Features

50,000 count [DM610: 5,000 count] auto ranging with full annunciator and analog bar graph.

All the functions are designed to be very convenient to use. You can quickly get used to working with this meter and the great many function integrated inside.

# 2. SAFETY CONSIDERATIONS











## 2.1 Safety Information: Read First

### Safety Precautions

Specific warning and caution statements, where they apply, will be found throughout the manual.

Before using this Meter, read the following safety information carefully. In this manual, the word WARNING is used for conditions and actions that hazard(s) to the user; the word CAUTION is used for conditions and actions that may damage this Meter.

**International Symbols** used on the Meter and in this manual are explained in the next table.

	Caution! See explanation in manual before using this Meter
	Dangerous Voltage
	Double Insulation (Protection Class II)
	Recycling information
	Equal potential inputs
	Earth (Ground)
	Either AC or DC
	DC - Direct Current
	AC - Alternating Current
	Fuse



## **WARNING!**

Exceeding the limits of this meter is dangerous. It will expose you to serious or possibly fatal injury. Carefully read and understand the cautions and the specification limits of this Meter.

- 1) Do not use this product to measure voltages that are over 1,000V DC or 750V AC RMS between any terminal and ground.
- 2) Voltage above 25V DC or AC RMS may constitute a serious shock hazard.
- 3) Do not attempt to use this Meter if either the Meter or the test leads has been damaged.
- 4) Use a current clamp to measure circuits exceeding 10A.
- 5) Avoid electrical shock; do not touch the test leads, tips or the circuit being tested.
- 6) Select the proper function and range for the measurement. Do not attempt voltage or current measurements that may exceed the input limit ratings marked on the switch or terminal.
- 7) Never connect more than one set of test leads to the Meter.
- 8) Disconnect the live test lead before disconnecting the common test lead.
- 9) Observe the maximum input limit as stated in the specification.
- 10) Disconnect the test lead from the test points before changing the meter function and range.
- 11) Do not continue measuring high current above 10A for more than 30sec. to avoid opening fuse and overheating circuits. The successive measurement should be done after more than 10 minutes for cooling down.
- 12) Do not attempt a current measurement where the voltage is above 250V.
- 13) Remove the test leads before opening the case to avoid electric shock.
- 14) Install only the fuses with the specified Amp/Volt Ratings.

### 3. EXPLANATION OF CONTROLS AND INDICATIONS

#### 3-1. PANEL CONFIGURATION

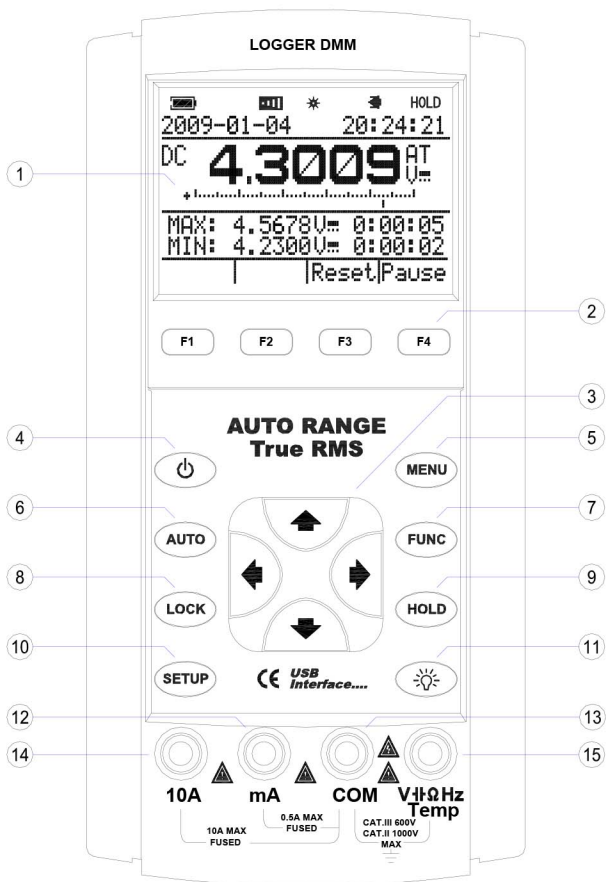

NOTE: The following description correspond to numbers on picture.

### 3-1-1. LCD DISPLAY

Displays the measurement data, setup menu, etc  
128 X 64 full dot matrix LCD with LED Back light..

### 3-1-2. Function Command Keys

F1 through F4 are command 'soft' keys.  
Their functions change with each screen.

### 3-1-3. Four Direction Arrow Keys

These keys serve as the primary means of navigating the instrument's menus and operating displays.

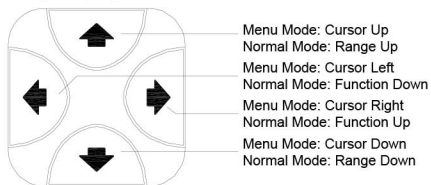

### 3-1-4. Power Switch

Pressing and holding this button for 2 to 3 seconds will turn the unit on. Pressing this button again will turn the power off.

### 3-1-5. MENU key

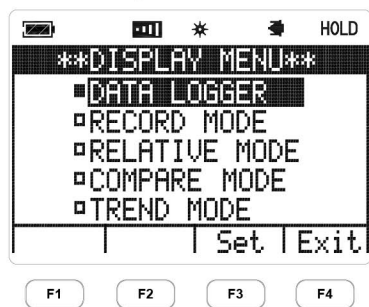

Press **MENU** key to open the **DISPLAY MENU**.

Use the  arrow keys to highlight an item.

Press **F3** to select an item

### 3-1-6. AUTO Key

This key is used for selecting the Auto range mode.

### 3-1-7. FUNCTION Key

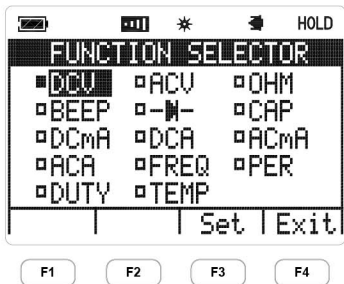

Press **FUNC** key to open the **FUNCTION SELECTOR** menu.

Use the  arrow keys to highlight an item.

Press **F3** to select an item

Item	Description
DC V	Measure DC 500mV, 5V,50V,500V,1000V
ACV	Measure AC mV, ACV
OHM	Measure Resistance..
BEEP	Measure Continuity and Diode.
DIODE	Measure Diode.
CAP	Measure Capacitance
DCmA	Measure DC milli-amps (50mA,500mA)
DCA	Measure DC amps (5A,10A)
ACmA	Measure AC milli-amps (50mA,500mA)
ACA	Measure AC amps (5A,10A)
FRQ	Measure Frequency.
PER	Measure Period.
DTY	Measure Duty cycle.
TEMP	Measure Temperature. (To be used "K" type Sensor)

### 3-1-8. LOCK Key

Disables all buttons on the front panel. Pressing this button again enables the front panel buttons.

### 3-1-9. HOLD Key

Freezes the displayed LCD value and displays an HOLD on the LCD.



### 3-1-10. SETUP Key

Set Beeper, Auto Power off, Temp Scale and Contrast of the METER

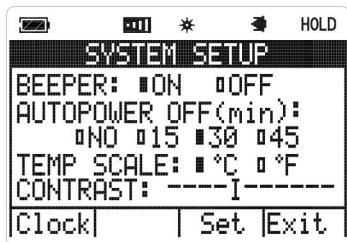

Press SETUP Key

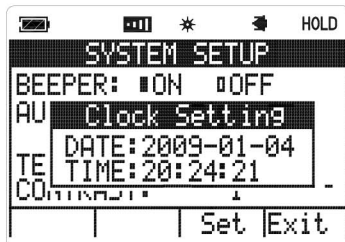

SETUP -> F1 (CLOCK)

### 3-1-11. Display Back Light Key

Press this button to turn on the backlight. To turn the back light off, press this button again.

### 3-1-12. mA (Milli-amp Input Terminal)

The red test lead is plugged into this terminal for measuring uA or mA on either AC or DC ampere functions.

### 3-1-13. COM (Common Terminal)

The black test lead is plugged into this terminal for all measurements. When measuring temperature, a thermocouple adapter is plugged into this terminal.

### 3-1-14. 10A (Amperes Input Terminal)

The red test lead is plugged into this terminal for measuring current in the 5A or 10A AC or DC ampere functions.

### 3-1-15. V, $\Omega$ , Hz, Temp Input Terminal

The red test lead is plugged into this terminal for all AC V, DC V, Frequency, Period, Duty, Pulse Width, Ohm, Continuity, Diode, Capacitance and Temperature functions. When measuring temperature, a thermocouple adapter is plugged into both this terminal and the COM input terminal.

### 3-2. LCD CONFIGURATION

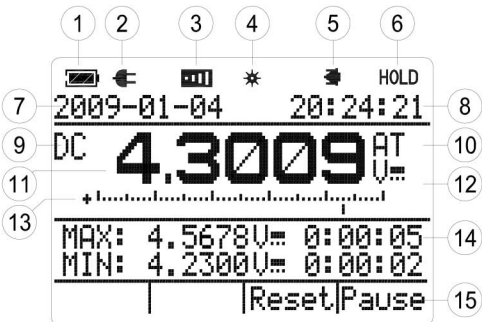

⑦ DATE: Display date of today

⑨ **Function annunciato**  
Display the current Function indicator.

⑪ **Measurement value**  
The current measured value is displayed along with the appropriate label or PASS/HI/LO when in the compare (COMP) mode

⑬ **Analog Bar-graph**  
The bar-graph provides an analog representation of readings. The bar-graph illuminates from left to right as the input increases

⑮ Menu Area

① : Low battery and battery level indicator.

② : USB or External power

③ : Continuity

④ : Back light

⑤ : USB interface link indicator with computer

⑥ HOLD : Data Hold

⑧ TIME: Display currently time

⑩ Auto Range Indicator

⑫ Range Annunciator

⑭ Program mode display. Refer to [35. Program mode display].

### 3-3. Display mode Menu Map.

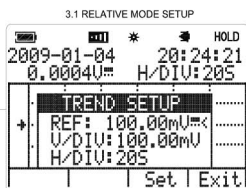
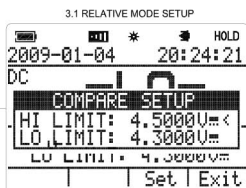
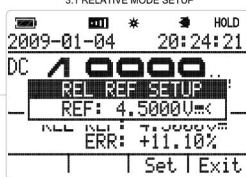
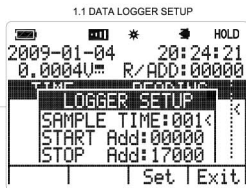
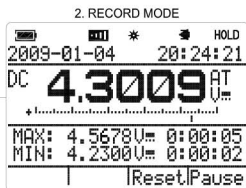
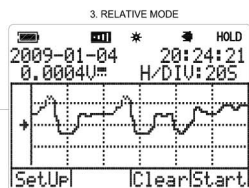
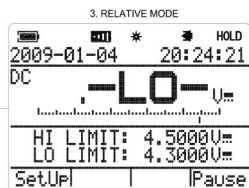
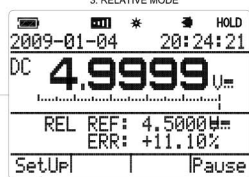
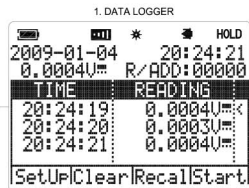

#### 1. DATA LOGGER

Press **MENU** key to open the **DISPLAY MENU**.

Use the  arrow keys to highlight an **DATA LOGGER**. And Press **F3** to set.

#### 2. RECORD MODE

Press **MENU** key to open the **DISPLAY MENU**.

Use the  arrow keys to highlight an **RECORD MODE** and Press **F3** to set.

#### 3. RELATIVE MODE

Press **MENU** key to open the **DISPLAY MENU**.

Use the  arrow keys to highlight an **RELATIVE MODE** and Press **F3** to set.

#### 4. COMARE MODE

Press **MENU** key to open the **DISPLAY MENU**.

Use the  arrow keys to highlight an **COMPARE MODE** and Press **F3** to set.

#### 5. TREND MODE

Press **MENU** key to open the **DISPLAY MENU**.

Use the  arrow keys to highlight an **TREND MODE** and Press **F3** to set.

## 4. GENERAL SPECIFICATION

### 4-1. DISPLAY

- 1) Type: DOT MATRIX LCD
  - 2) View area: 47 x 62 mm
  - 3) Back light (Auto light off: Approximately 35 Sec.)
  - 4) Bar graph: 42 segments (Displays 20 times per sec.)
  - 5) Polarity display: Only displays “\_”
  - 6) Overload indication: Displays “OL”
  - 7) Other displays: When this Meter is turned on, all display segments and symbols appear briefly during a self test.
- \* Digit display: Displays 2.5 or 5 times per sec.  
\* Frequency, Dwell: Displays 0.5~5 times per sec.

### 4-2. ENVIRONMENTAL

Item	Operating	Storage
Temperature	0 to 50°C (32 to 122°F)	-40 to 70°C (-22 to 158°F)
Humidity	80% RH max. No wetting	95% RH max. Battery removed

\* Temp coefficient: 0.1 x (Specified accuracy)/ °C  
For (0 to 18°C or 28 to 50°C (32 to 64°F or 82 to 122°F))

### 4-3. MAXIMUM INPUT & PROTECTION TYPE

Rotary Switch	V-COM	mA-COM	10A-COM	Protection
DCV/ACV	1,000V Peak			10MΩ
AC V / Hz	1,000V Peak			10MΩ
AC/DC mA		F600V, 0.5A		Fuse
AC/DC A			F600V, 10A	Fuse
Ohm/Continuity Diode,Capacitance	250V rms			PTC 1kΩ
Temperature	250V rms			PTC 1kΩ

#### **4-4. POWER SUPPLY**

- 1) Type Li-ion Battery 3.7V
- 2) Auto power off: If this Meter is on and inactive for approximately 15,30,45 minutes user selectable, this Meter will automatically switch to Auto-Power-Off mode.

#### **4-5. MECHANICAL**

- 1) Dimension: 99(W) x 199(L) x 40(H) mm
- 2) Weight: 590

#### **4-6. ACCESSORY**

##### **4.6.1. Basic:**

- |                            |       |
|----------------------------|-------|
| 1) Test lead (Red & Black) | 1 set |
| 2) Holster                 | 1 pcs |
| 3) Instruction manual      | 1 pcs |
| 3) Carrying Case           | 1 pcs |
| 4) USB Cable               | 1 pcs |
| 5) Demonstration Software  | 1 pcs |

##### **4.6.2. Option:**

- |   |       |
|---|-------|
| 1) Thermo couple temperature probe (TP35, "K" Type) | 1 pcs |
|---|-------|

## 5. ELECTRICAL SPECIFICATIONS

\* Accuracy in specified at 23°C ± 5°C (75°F ± 9°F) with relative humidity up to 80% for a period of one year after calibration.

### 5-1. DC V

Meter	Range	Resolution	Accuracy	Impedance	Max. Input Voltage
DM620	500mV	0.01mV	±(0.05%+5d)	10 MΩ	1,000 VDC or 750 VAC rms
	5 V	0.0001V			
	50 V	0.001V			
	500 V	0.01V			
	1000 V	0.1V			
DM610	500mV	0.1mV	±(0.1%+5d)	10 MΩ	1,000 VDC or 750 VAC rms
	5 V	0.001V			
	50 V	0.01V			
	500 V	0.1V			
	1000 V	1V			

### 5-2. AC V

Meter	Range	Resolution	Accuracy		Impedance	Max. input Voltage
			45~450Hz	450~10kHz		
DM620	500mV	0.01mV	±(0.75%+20d)	±(3%+20d)	10 MΩ	1000 VDC or 750 VAC rms
	5 V	0.0001V				
	50 V	0.001V				
	500 V	0.01V				
	1000 V	0.1V				
DM610	500mV	0.1mV	±(0.75%+20d)	±(3%+20d)	10 MΩ	1,000 VDC or 750 VAC rms
	5 V	0.001V				
	50 V	0.01V				
	500 V	0.1V				
	1000 V	1V				

#### Note

Conversion: True RMS

Input: AC Coupling

### 5-3. Resistance

Meter	Range	Resolution	Accuracy	Protection
DM620	500 $\Omega$	0.01 $\Omega$	$\pm(0.1\%+5d)$	600 V DC or 600 V AC Peak
	5 k $\Omega$	0.0001 k $\Omega$		
	50 k $\Omega$	0.001 k $\Omega$		
	500 k $\Omega$	0.01 k $\Omega$	$\pm(1\%+10d)$	
	5 M $\Omega$	0.0001 M $\Omega$		
	20 M $\Omega$	0.001 M $\Omega$		
DM610	500 $\Omega$	0.1 $\Omega$	$\pm(0.5\%+5d)$	600 V DC or 600 V AC Peak
	5 k $\Omega$	0.001 k $\Omega$		
	50 k $\Omega$	0.01 k $\Omega$		
	500 k $\Omega$	0.1 k $\Omega$	$\pm(1\%+10d)$	
	5 M $\Omega$	0.001 M $\Omega$		
	20 M $\Omega$	0.01 M $\Omega$		

#### Note

Test leads for 2 and 20M measurement should be short enough to avoid instability due to external noise.

It is recommended to use a shielded cable for long distance

### 5-4. Continuity

Meter	Range	Resolution	Threshold	Protection
DM620	5 k $\Omega$	0.0001 k $\Omega$	Less than 100 ohm	600 V DC or V AC Peak
DM610	5k $\Omega$	0.001 k $\Omega$	Less than 100 ohm	600 V DC or V AC Peak

### 5-5. Diode Test

Meter	Range	Resolution	Max. Test Current	Open circuit voltage	Protection
DM620	3 V	0.0001V	Approx. 2.5mA	3V	600 V DC or VAC Peak
DM610	3V	0.001V	Approx. 2.5mA	3V	600 V DC or VAC Peak

## 5-6. Capacitance

Meter	Range	Resolution	Accuracy	Protection
DM610	500 nF	0.1 nF	±(4%+15d)	±250V
	5 uF	0.001 uF		
DM620	50 uF	0.01 uF		
	500 uF	0.1 uF		

## 5-7. Frequency

Meter	Range	Resolution	Accuracy	Protection
DM610	1000Hz	0.01Hz	±(0.05%+2d)	±250V
	10kHz	0.0001Hz		
DM620	100kHz	0.001kHz		
	1MHz	0.00001kHz		
	10MHz	0.0001MHz	Unspecified	
	100MHz	0.001MHz		

## 5-8. Period

Meter	Range	Resolution	Accuracy	Protection
DM610 DM620	1 uS	0.0001uS	±(0.05%+2d)	±250V
	10 uS	0.001uS		
	100 uS	0.01uS		
	1 mS	0.0001mS		
	10 mS	0.001mS		
	100 mS	0.01mS		
	1 S	0.0001S		

## 5-9. Duty cycle

Meter	Range	Resolution	Accuracy	Input Frequency
	100%	0.1%	±(0.1%+2d)	Less than 1kHz

## 5-10. Temperature

Meter	Range	Resolution	Accuracy	Protection
	1370°C	1°C	±(5%+3d)	600 V DC or AC Peak
	2498°F	1°F		

### Note

1. Temp. Sensor Type: "K" Type thermo-Couple.
2. Room Temperature is displayed with no sensor probe connected.



**5-11. DCm A**

Meter	Range	Resolution	Accuracy	Max. Burden	Protection
DM620	50 mA	0.001mA	$\pm(0.1\%+5d)$	500mV	0.5A/ 600V
	500mA	0.01mA			
DM610	50 mA	0.01uA	$\pm(0.5\%+5d)$	500mV	0.5A/ 600V
	500mA	0.1mA			

**5-11. DC A**

Meter	Range	Resolution	Accuracy	Max. Burden	Protection
DM620	5A	0.0001A	$\pm(0.1\%+5d)$	500mV	0.5A/ 600V
	10A	0.001A			
DM610	5A	0.001A	$\pm(0.5\%+5d)$	500mV	0.5A/ 600V
	10A	0.01A			

**5-15. AC mA, 50 ~ 500 Hz**

Meter	Range	Resolution	Accuracy	Max. Burden	Protection
DM620	50 mA	0.001mA	$\pm(0.75\%+20d)$	500mV	0.5A/ 600V
	500mA	0.01mA			
DM610	50 mA	0.01uA	$\pm(0.75\%+20d)$	500mV	0.5A/ 600V
	500mA	0.1mA			

**5-16. AC A, 50 ~ 500 Hz**

Meter	Range	Resolution	Accuracy	Max. Burden	Protection
DM620	5A	0.0001A	$\pm(0.75\%+20d)$	500mV	0.5A/ 600V
	10A	0.001A			
DM610	5A	0.001A	$\pm(0.75\%+20d)$	500mV	0.5A/ 600V
	10A	0.01A			

**Note**

1. Conversion: True RMS

## 6. ELECTRICAL TESTS AND MEASUREMENTS

One of the most common electrical diagnostic tools is a Digital MultiMeter (DMM). A DMM is simply an electronic yardstick for making electrical measurements.

DMMs have many special functions and features, but the most common use is to measure voltage, current, capacitance and resistance.

An digital Multimeter such as the this meter can also measure frequency, period, duty cycle, pulse width, temperature and even the condition of diodes.

### Voltage Measurements

**CAUTION!** Do not attempt to make a voltage measurement if a test lead is plugged in the A or mA input jack, instrument damage and/or personal injury may result.



**WARNING!** To avoid the risk of electrical shock and instrument damage, input voltages must not exceed 1,000V DC or 750V AC rms. Do not attempt to make any unknown voltage measurement that may be in exceed of 1, 000V DC or 750V AC rms.



#### 6-1. DC V

- 1) Insert the BLACK test lead into the input socket marked as “COM”.
- 2) Insert the RED test lead into the input socket marked as “V $\|$  $\Omega$ Hz”.
- 3) Select **DCV** with the **FUNC** Menu..
- 4) Attach the probe tips to the voltage source.

The LCD will display the measured value along with the Bar graph.

If the voltage is too high, the measurement range will be changed to the next higher range automatically. Then the range is in the highest or in the manual range, too high voltage makes the display read “OL”.

#### 6-2. AC V

- 1) Insert the BLACK test lead into the input socket marked as “COM”.
- 2) Insert the RED test lead into the input socket marked as “V $\|$  $\Omega$ Hz”.
- 3) Select **ACV** with the **FUNC** Menu..

#### 6-3. RESISTANCE

- 1) Insert the BLACK test lead into the input socket marked as “COM”.
- 2) Insert the RED test lead into the input socket marked as “V $\|$  $\Omega$ Hz”.
- 3) Select **OHM** with the **FUNC** Menu.

“Open” leads will display “OL” appeared on the display.

“Shorting” the test leads will display zero or extremely low value resistance (Test Lead Resistance).

### Resistance Measurements

**WARNING!** Turn off power and discharge all capacitors in the circuit to be tested before making in-circuit resistance measurements. Accurate measurement is not possible if external or residual voltage is present.



#### 6-6. CONTINUTY

- 1) Insert the **BLACK** test lead into the input socket marked as "**COM**".
- 2) Insert the **RED** test lead into the input socket marked as "**V $\Omega$ Hz**".
- 3) Select **BEEP** with the **FUNC** Menu.

#### 6-7. DIODE

- 1) Insert the **BLACK** test lead into the input socket marked as "**COM**".
- 2) Insert the **RED** test lead into the input socket marked as "**V $\Omega$ Hz**".
- 3) Select **DIODE** with the **FUNC** Menu.

### Capacitance Measurements

**WARNING!** All capacitance measurements are to be made on de-energized circuits with all capacitors discharged only. Failure to de-energize and discharge capacitors before attempting to measure them could result in instrument damage and/or personal injury.



#### 6-8. CAPACITANCE

- 1) Insert the **BLACK** test lead into the input socket marked as "**COM**".
- 2) Insert the **RED** test lead into the input socket marked as "**V $\Omega$ Hz**".
- 3) Select **CAP** with the **FUNC** Menu.

### Frequency Measurements

**WARNING!** Never attempt a frequency measurement with a voltage source greater than 600V. Determine the voltage of any unknown frequency source before connecting the instrument in frequency mode.



#### 6-9. Frequency

- 1) Insert the **BLACK** test lead into the input socket marked as "**COM**".
- 2) Insert the **RED** test lead into the input socket marked as "**V $\Omega$ Hz**".
- 3) Select **FRQ** with the **FUNC** Menu.

#### 6-10. Period

- 1) Insert the **BLACK** test lead into the input socket marked as "**COM**".
- 2) Insert the **RED** test lead into the input socket marked as "**V $\Omega$ Hz**".
- 3) Select **PER** with the **FUNC** Menu.

### 6-11. Duty

- 1) Insert the BLACK test lead into the input socket marked as “COM”.
- 2) Insert the RED test lead into the input socket marked as “V $\Omega$ Hz”.
- 3) Select **DTY** with the **FUNC** Menu.

### Temperature Measurements

**WARNING!** Do not allow temperature probes to contact any live voltage that may exceed 30V AC or 42V peak or 60V DC. Unplug temperature probe before taking measurements other than temperature. Keep the meter away from sources of very high temperatures to prevent damage. For maximum temperature probe life, avoid exposure to very high temperatures (operating range -4°F to 2,192°F).



### 6-13. TEMPERATURE

- 1) Select **Temp** with the **FUNC** Menu.
- 2) Connect the thermocouple(K type) to the meter **COM(-)** + **V $\Omega$ Hz(+)**.

\* Abrupt change in ambient temperature can make a measurement error. So about 30 minutes of setting time necessary for the changed ambient.  
Temperature to be reached to the sensor inside the case.

### Current Measurements

**CAUTION!** Do not attempt to make a current measurement with the test leads connected parallel with the circuit to be tested. Test leads must be connected in series with the circuit.



**WARNING!** The current functions are protected by 600 volt fuse. To avoid damage to the meter, current sources having open circuit voltages greater than 600 volts DC or AC must not be measured.



#### 6-17. DC mA

- 1) Insert the BLACK test lead into the input socket marked as "**COM**".
- 2) Insert the RED test lead into the input socket marked as "**mA**".
- 3) Select **DCmA** with the **FUNC** Menu.

If the measured current is too high, the display will indicate "OL". In this case, the higher current range (10A) should be selected.

#### 6-20. DC A

- 1) Insert the BLACK test lead into the input socket marked as "**COM**".
  - 2) Insert the RED test lead into the input socket marked as "**10A**".
  - 3) Select **DCA** with the **FUNC** Menu.
- \* Do not continue measuring current above 10A for more than 30sec.to avoid opening fuse or overheating.

#### 6-18. ACmA

- 1) Insert the BLACK test lead into the input socket marked as "**COM**".
- 2) Insert the RED test lead into the input socket marked as "**mA**".
- 3) Select **ACmA** with the **FUNC** Menu

If the measured current is too high, the display will indicate "OL". In this case, the higher current range (10A) should be selected.

#### 6-21. AC A

- 1) Insert the BLACK test lead into the input socket marked as "**COM**".
- 2) Insert the RED test lead into the input socket marked as "**10A**".
- 3) Select **ACA** with the **FUNC** Menu.

## **7. USB INTERFACE & Battery Chaging**

### **7-1. USB Cable Connection**

Connect the USB cable to the built-in USB connector in the Meter and to the PC USB port.

### **7-2. Human Interface Device (HID) Spec.**

USB interface: HID(Human Interface Device)

USB specification 2.0 compliant

Full speed (12 Mbps) or low speed (1.5 Mbps) operation

Vendor ID: 10C4

Product ID: EE01

Packet Length: 64 byte

### **7-3. Installation of Supplied Software**

The supplied software programs run on MS windows.

Insert the supplied diskette into the Drive A. (or B).

Select File from the Program Manager screen, then select Run.

Type A:\(or B:\) SETUP. Then ENTER.

### **7-4. Communication with PC**

For detailed operation method, refer to the “readme.doc” file in the supplied diskette.

## 8. MAINTENANCE

### 8-1. GENERAL

- 1) Do not use abrasives or solvents and Periodically wipe the case with a damp cloth and detergent.
- 2). Calibrate the meter once a year to maintain its accuracy specification.

### 8-2. FUSE REPLACEMENT

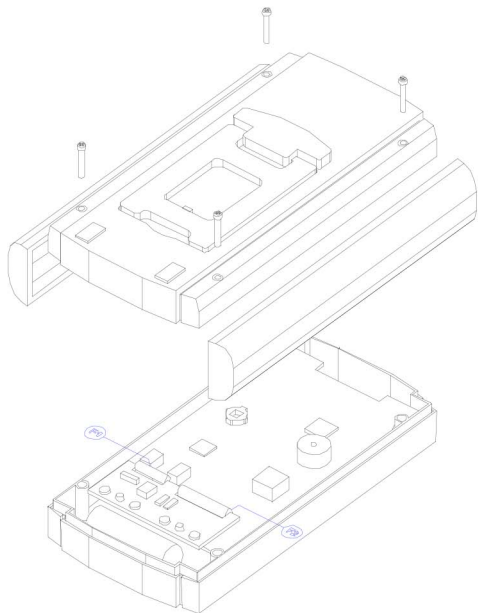

Replacing the defective fuses should be done according to the following procedure.

- 1) To avoid electrical shock, remove the test leads and any input signal before opening the case.
- 2) Remove the Holster, and remove the four screw from the button case.
- 3) Lift the button case until it gently unsnaps from the top case.
- 4) Remove the defective fuse by gently prying loose one end of the fuse and sliding the fuse from the fuse holder.
- 5) Install a new fuse of the same size and rating, Ensure that the new fuse is centered in the fuse holder.
- 6) Replace the button case, and reinstall all the screws.

#### Note

Testing the internal fuse

- 1) Plug a test lead into the V input socket and touch the test lead tip to the mA input socket.
- 2) Set the rotary switch to  $\Omega$ . The display should read between 0 and  $1\Omega$ .  
A defective fuse will display reading more than  $1\Omega$ .