

Deluxe Rack Case Assembly



Model

1 Unit Black Powdercoated

H 5035

2 Unit Black Powdercoated

H 5036

Parts List

- 1 x Unvented Bottom Plate
- 2 x Side Plates with integral ears
- 1 x Vented Top Plate
- 1 x Bevelled Front Panel
- 1 x Rear Panel
- 26 x M3 10mm Countersunk Bolts

Step 1: Ensure that you have done all the machining to the case that you intend doing. It is much easier to machine before it is assembled. Take the unvented bottom panel and attach the sides using the 3mm bolts. Do this for both side pieces.

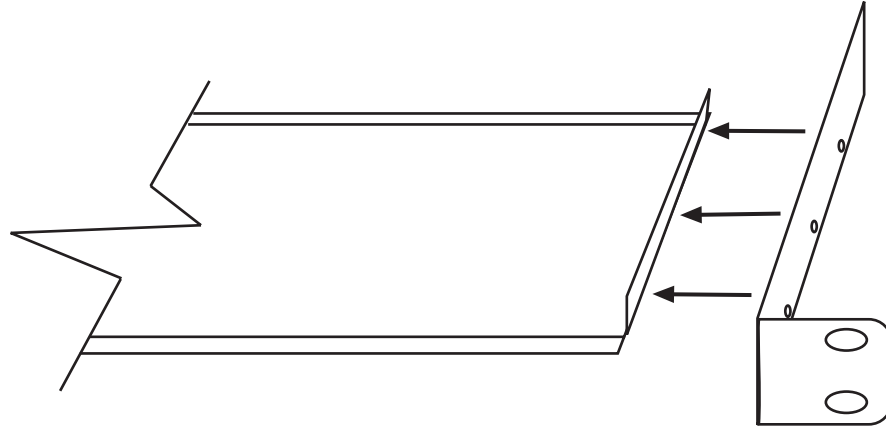

Step 2: After you attach both sides you may attach the front and back. Note, the front and back panel fits under the lip. Again use the 3mm bolts provided.

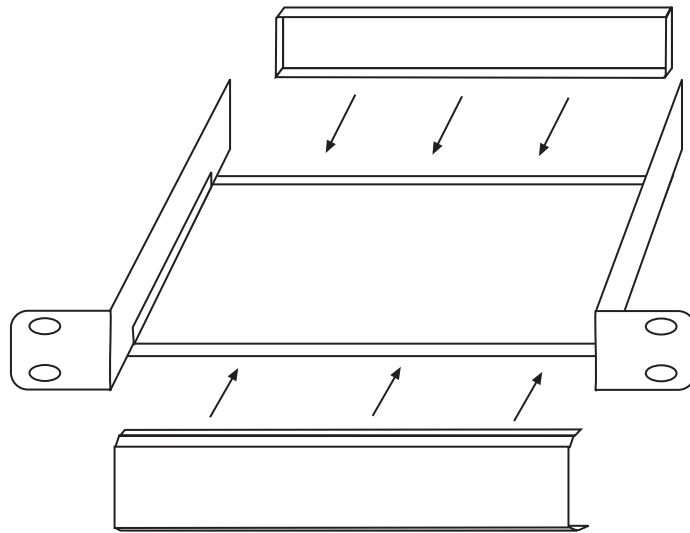

Step 3: Once the project is in place you should take the vented top piece and slide this into place. The joggled lip fits under the lip of the front panel and is secured into place with the remaining 3mm bolts.

