

LM386M-1/LM386MX-1 Low Voltage Audio Power Amplifier

1 Features

- Battery Operation
- Minimum External Parts
- Wide Supply Voltage Range: 4 V–12 V or 5 V–18 V
- Low Quiescent Current Drain: 4 mA
- Voltage Gains from 20 to 200
- Ground-Referenced Input
- Self-Centering Output Quiescent Voltage
- Low Distortion: 0.2% ($A_V = 20$, $V_S = 6$ V, $R_L = 8$ Ω , $P_O = 125$ mW, $f = 1$ kHz)
- Available in 8-Pin MSOP Package

2 Applications

- AM-FM Radio Amplifiers
- Portable Tape Player Amplifiers
- Intercoms
- TV Sound Systems
- Line Drivers
- Ultrasonic Drivers
- Small Servo Drivers
- Power Converters

3 Description

The LM386M-1 and LM386MX-1 are power amplifiers designed for use in low voltage consumer applications. The gain is internally set to 20 to keep external part count low, but the addition of an external resistor and capacitor between pins 1 and 8 will increase the gain to any value from 20 to 200.

The inputs are ground referenced while the output automatically biases to one-half the supply voltage. The quiescent power drain is only 24 mW when operating from a 6-V supply, making the LM386M-1 and LM386MX-1 ideal for battery operation.

Device Information⁽¹⁾

PART NUMBER	PACKAGE	BODY SIZE (NOM)
LM386N-1	PDIP (8)	9.60 mm x 6.35 mm
LM386N-3	PDIP (8)	9.60 mm x 6.35 mm
LM386N-4	PDIP (8)	9.60 mm x 6.35 mm
LM386M-1	SOIC (8)	4.90 mm x 3.90 mm
LM386MX-1	SOIC (8)	4.90 mm x 3.90 mm
LM386MMX-1	VSSOP (8)	3.00 mm x 3.00 mm

(1) For all available packages, see the orderable addendum at the end of the data sheet.

Figure 1. Schematic

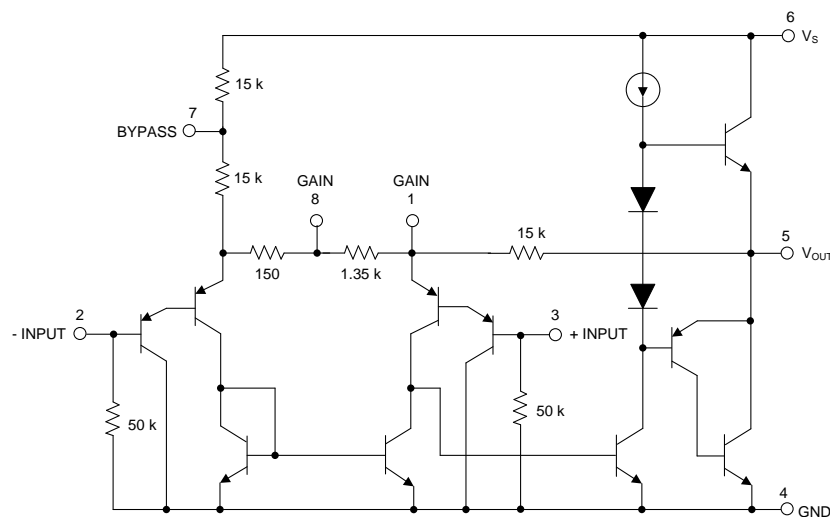

Table of Contents

1 Features	1	9 Application and Implementation	8
2 Applications	1	9.1 Application Information.....	8
3 Description	1	9.2 Typical Application	8
4 Revision History	2	10 Power Supply Recommendations	15
5 Pin Configuration and Functions	3	11 Layout	16
6 Specifications	3	11.1 Layout Guidelines	16
6.1 Absolute Maximum Ratings	3	11.2 Layout Examples.....	16
6.2 ESD Ratings	3	12 Device and Documentation Support	18
6.3 Recommended Operating Conditions.....	4	12.1 Device Support.....	18
6.4 Thermal Information	4	12.2 Documentation Support	18
6.5 Electrical Characteristics.....	4	12.3 Related Documentation	18
6.6 Typical Characteristics.....	5	12.4 Related Links	18
7 Parameter Measurement Information	6	12.5 Community Resources.....	18
8 Detailed Description	7	12.6 Trademarks	18
8.1 Overview	7	12.7 Electrostatic Discharge Caution.....	18
8.2 Functional Block Diagram	7	12.8 Glossary	18
8.3 Feature Description.....	7	13 Mechanical, Packaging, and Orderable	
8.4 Device Functional Modes.....	7	Information	19

4 Revision History

NOTE: Page numbers for previous revisions may differ from page numbers in the current version.

Changes from Revision A (May 2004) to Revision B	Page
• Added LM386MX-1 device to the data sheet.	1
• Added Device Information, Application and Implementation, Power Supply Recommendation, Layout, and Device and Documentation Support sections.....	1
• Inserted Functional Block Diagram.....	7

5 Pin Configuration and Functions

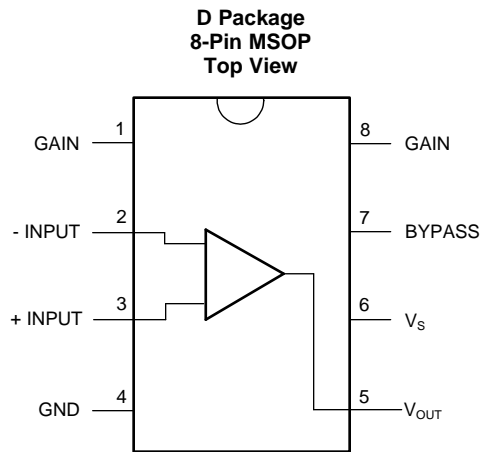

Pin Functions

PIN		TYPE	DESCRIPTION
NAME	NO.		
GAIN	1	–	Gain setting pin
–INPUT	2	I	Inverting input
+INPUT	3	I	Noninverting input
GND	4	P	Ground reference
V _{OUT}	5	O	Output
V _S	6	P	Power supply voltage
BYPASS	7	O	Bypass decoupling path
GAIN	8	–	Gain setting pin

6 Specifications

6.1 Absolute Maximum Ratings

over operating free-air temperature range (unless otherwise noted)⁽¹⁾

		MIN	MAX	UNIT
Supply Voltage, V _{CC}	LM386N-1/-3, LM386M-1		15	V
	LM386N-4		22	
Package Dissipation	LM386N		1.25	W
	LM386M		0.73	
	LM386MM-1		0.595	
Input Voltage, V _I		–0.4	0.4	V
Storage temperature, T _{stg}		–65	150	°C

(1) Stresses beyond those listed under *Absolute Maximum Ratings* may cause permanent damage to the device. These are stress ratings only, which do not imply functional operation of the device at these or any other conditions beyond those indicated under *Recommended Operating Conditions*. Exposure to absolute-maximum-rated conditions for extended periods may affect device reliability.

6.2 ESD Ratings

		VALUE	UNIT
V _(ESD) Electrostatic discharge	Human-body model (HBM), per ANSI/ESDA/JEDEC JS-001 ⁽¹⁾	±1000	V
	Charged-device model (CDM), per JEDEC specification JESD22-C101 ⁽²⁾	±1000	

(1) JEDEC document JEP155 states that 500-V HBM allows safe manufacturing with a standard ESD control process.

(2) JEDEC document JEP157 states that 250-V CDM allows safe manufacturing with a standard ESD control process.

6.3 Recommended Operating Conditions

over operating free-air temperature range (unless otherwise noted)

		MIN	NOM	MAX	UNIT
VCC	Supply Voltage	4		12	V
	LM386N-4	5		18	V
	LM386N-4	4			Ω
VI	Analog input voltage	-0.4		0.4	V
TA	Operating free-air temperature	0		70	$^{\circ}\text{C}$

6.4 Thermal Information

THERMAL METRIC ⁽¹⁾		LM386	LM386	LM386	UNIT
		D (SOIC)	DGK (VSSOP)	P (PDIP)	
		8	8	8	
R _{θJA}	Junction-to-ambient thermal resistance	115.7	169.3	53.4	$^{\circ}\text{C}/\text{W}$
R _{θJC(top)}	Junction-to-case (top) thermal resistance	59.7	73.1	42.1	$^{\circ}\text{C}/\text{W}$
R _{θJB}	Junction-to-board thermal resistance	56.2	100.2	30.6	$^{\circ}\text{C}/\text{W}$
ψ _{JT}	Junction-to-top characterization parameter	12.4	9.2	19.0	$^{\circ}\text{C}/\text{W}$
ψ _{JB}	Junction-to-board characterization parameter	55.6	99.1	50.5	$^{\circ}\text{C}/\text{W}$

(1) For more information about traditional and new thermal metrics, see the [Semiconductor and IC Package Thermal Metrics](#) application report.

6.5 Electrical Characteristics

over operating free-air temperature range (unless otherwise noted)

PARAMETER		TEST CONDITIONS		MIN	TYP	MAX	UNIT
V _S	Operating Supply Voltage	LM386N-1, -3, LM386M-1, LM386MM-1		4		12	V
		LM386N-4		5		18	
I _Q	Quiescent Current	V _S = 6 V, V _{IN} = 0			4	8	mA
P _{OUT}	Output Power	V _S = 6 V, R _L = 8 Ω , THD = 10% (LM386N-1, LM386M-1, LM386MM-1)		250	325		mW
		V _S = 9 V, R _L = 8 Ω , THD = 10% (LM386N-3)		500	700		
		V _S = 16 V, R _L = 32 Ω , THD = 10% (LM386N-4)		700	100		
A _V	Voltage Gain	V _S = 6 V, f = 1 kHz			26		dB
		10 μF from Pin 1 to 8			46		
BW	Bandwidth	V _S = 6 V, Pins 1 and 8 Open			300		kHz
THD	Total Harmonic Distortion	V _S = 6 V, R _L = 8 Ω , P _{OUT} = 125 mW f = 1 kHz, Pins 1 and 8 Open			0.2%		
PSRR	Power Supply Rejection Ratio	V _S = 6 V, f = 1 kHz, CBYPASS = 10 μF Pins 1 and 8 Open, Referred to Output			50		dB
R _{IN}	Input Resistance				50		k Ω
I _{BIAS}	Input Bias Current	V _S = 6 V, Pins 2 and 3 Open			250		nA

6.6 Typical Characteristics

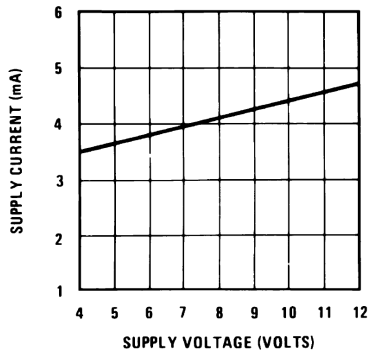

Figure 2. Supply Current vs Supply Voltage

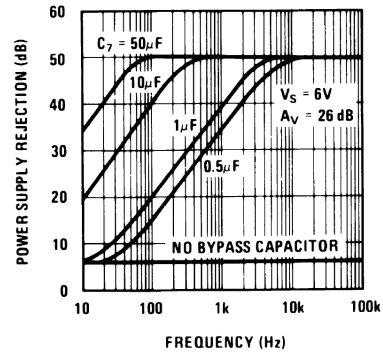

Figure 3. Power Supply Rejection vs Frequency

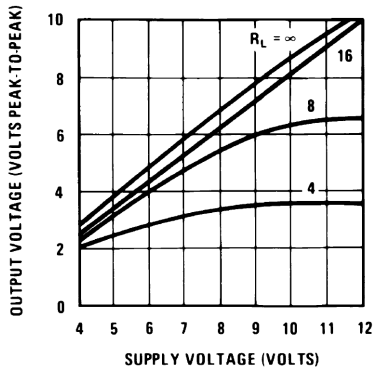

Figure 4. Output Voltage vs Supply Voltage

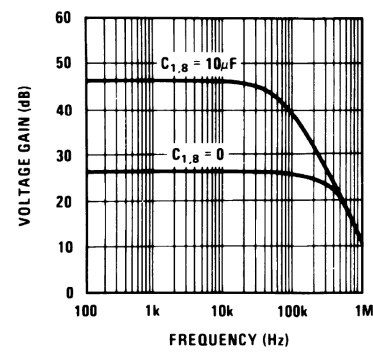

Figure 5. Voltage Gain vs Frequency

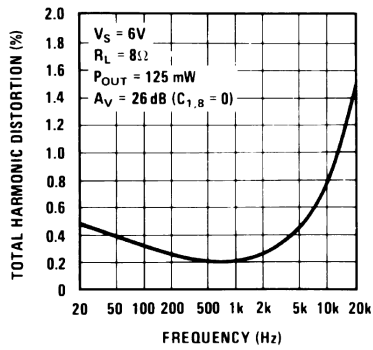

Figure 6. Total Harmonic Distortion vs Frequency

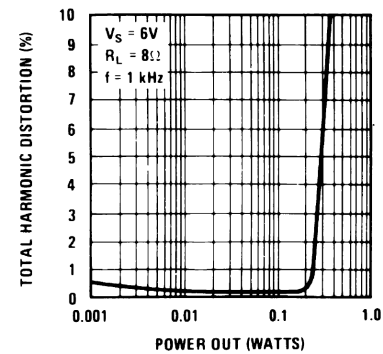
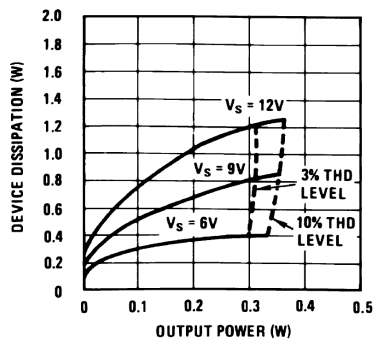
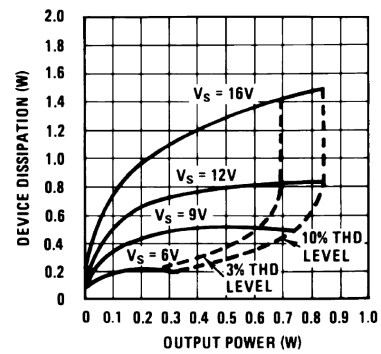
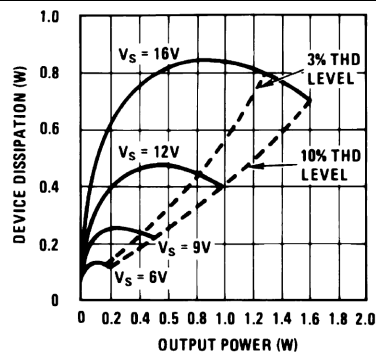

Figure 7. Total Harmonic Distortion vs Power Out

Typical Characteristics (continued)

Figure 8. Device Dissipation vs Output Power

Figure 9. Device Dissipation vs Output Power

Figure 10. Device Dissipation vs Output Power
7 Parameter Measurement Information

All parameters are measured according to the conditions described in the [Specifications](#) section.

8 Detailed Description

8.1 Overview

The LM386 is a mono low voltage amplifier that can be used in a variety of applications. It can drive loads from 4 Ω to 32 Ω . The gain is internally set to 20 but it can be modified from 20 to 200 by placing a resistor and capacitor between pins 1 and 8. This device comes in three different 8-pin packages as PDIP, SOIC and VSSOP to fit in different applications.

8.2 Functional Block Diagram

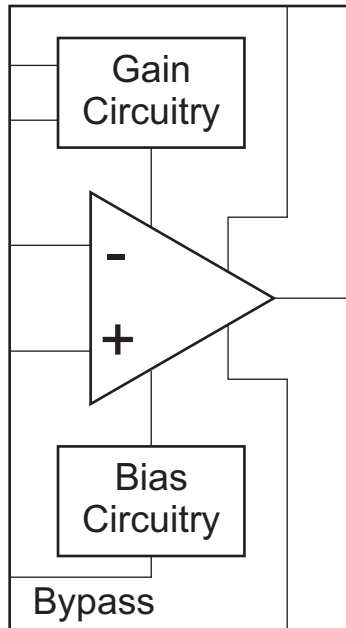

8.3 Feature Description

There is an internal 1.35-K Ω resistor that sets the gain of this device to 20. The gain can be modified from 20 to 200. Detailed information about gain setting can be found in the [Detailed Design Procedure](#) section.

8.4 Device Functional Modes

As this is an Op Amp it can be used in different configurations to fit in several applications. The internal gain setting resistor allows the LM386 to be used in a very low part count system. In addition a series resistor can be placed between pins 1 and 5 to modify the gain and frequency response for specific applications.

9 Application and Implementation

NOTE

Information in the following applications sections is not part of the TI component specification, and TI does not warrant its accuracy or completeness. TI's customers are responsible for determining suitability of components for their purposes. Customers should validate and test their design implementation to confirm system functionality.

9.1 Application Information

Below are shown different setups that show how the LM386 can be implemented in a variety of applications.

9.2 Typical Application

9.2.1 LM386 with Gain = 20

Figure 11 shows the minimum part count application that can be implemented using LM386. Its gain is internally set to 20.

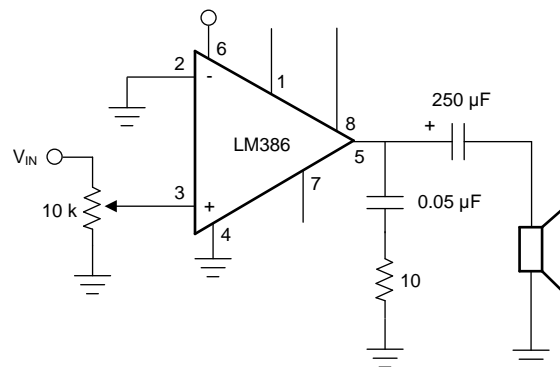

Copyright © 2017, Texas Instruments Incorporated

Figure 11. LM386 with Gain = 20

9.2.1.1 Design Requirements

DESIGN PARAMETER	EXAMPLE VALUE
Load Impedance	4 Ω to 32 Ω
Supply Voltage	5 Ω to 12 Ω

9.2.1.2 Detailed Design Procedure

9.2.1.2.1 Gain Control

To make the LM386 a more versatile amplifier, two pins (1 and 8) are provided for gain control. With pins 1 and 8 open the 1.35-kΩ resistor sets the gain at 20 (26 dB). If a capacitor is put from pin 1 to 8, bypassing the 1.35-kΩ resistor, the gain will go up to 200 (46 dB). If a resistor is placed in series with the capacitor, the gain can be set to any value from 20 to 200. Gain control can also be done by capacitively coupling a resistor (or FET) from pin 1 to ground.

Additional external components can be placed in parallel with the internal feedback resistors to tailor the gain and frequency response for individual applications. For example, we can compensate poor speaker bass response by frequency shaping the feedback path. This is done with a series RC from pin 1 to 5 (paralleling the internal 15-kΩ resistor). For 6 dB effective bass boost: $R = 15 \text{ kW}$, the lowest value for good stable operation is $R = 10 \text{ kW}$ if pin 8 is open. If pins 1 and 8 are bypassed then R as low as 2 kW can be used. This restriction is because the amplifier is only compensated for closed-loop gains greater than 9.

9.2.1.2.2 Input Biasing

The schematic shows that both inputs are biased to ground with a 50 kW resistor. The base current of the input transistors is about 250 nA, so the inputs are at about 12.5 mV when left open. If the dc source resistance driving the LM386 is higher than 250 kW it will contribute very little additional offset (about 2.5 mV at the input, 50 mV at the output). If the dc source resistance is less than 10 kW, then shorting the unused input to ground will keep the offset low (about 2.5 mV at the input, 50 mV at the output). For dc source resistances between these values we can eliminate excess offset by putting a resistor from the unused input to ground, equal in value to the dc source resistance. Of course all offset problems are eliminated if the input is capacitively coupled.

When using the LM386 with higher gains (bypassing the 1.35 kW resistor between pins 1 and 8) it is necessary to bypass the unused input, preventing degradation of gain and possible instabilities. This is done with a 0.1 μF capacitor or a short to ground depending on the dc source resistance on the driven input.

9.2.1.3 Application Curves

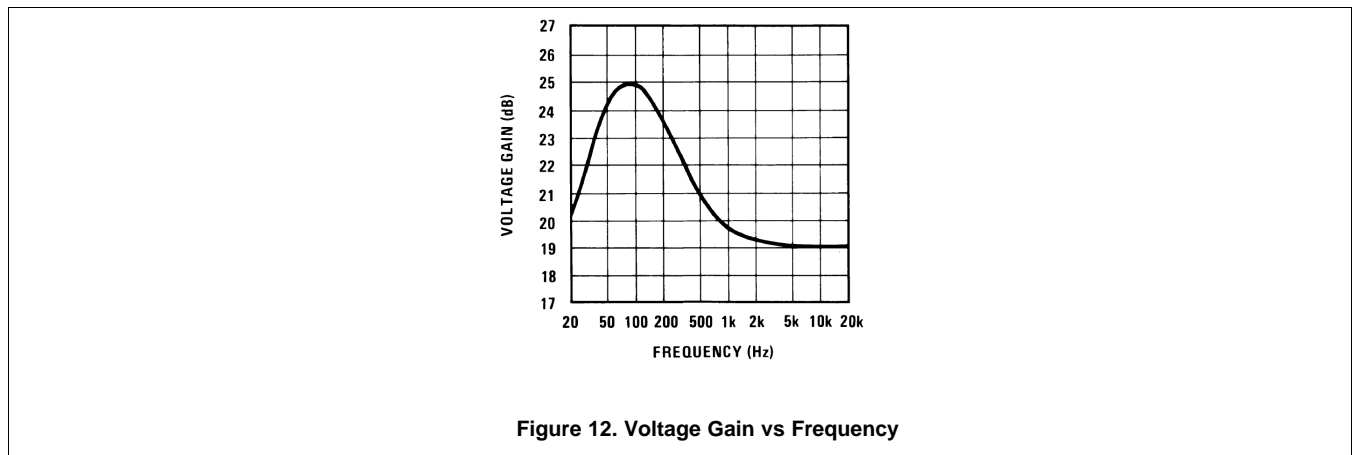

9.2.2 LM386 with Gain = 200

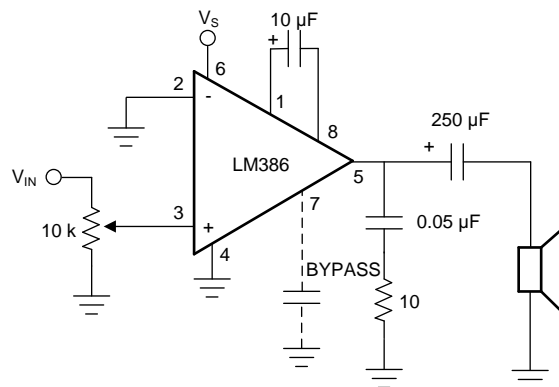

Copyright © 2017, Texas Instruments Incorporated

Figure 13. LM386 with Gain = 200

9.2.2.1 Design Requirements

DESIGN PARAMETER	EXAMPLE VALUE
Load Impedance	4 Ω to 32 Ω
Supply Voltage	5 Ω to 12 Ω

9.2.2.2 Detailed Design Procedure

The Detailed Design Procedure can be found in the [Detailed Design Procedure](#) section.

9.2.2.3 Application Curves

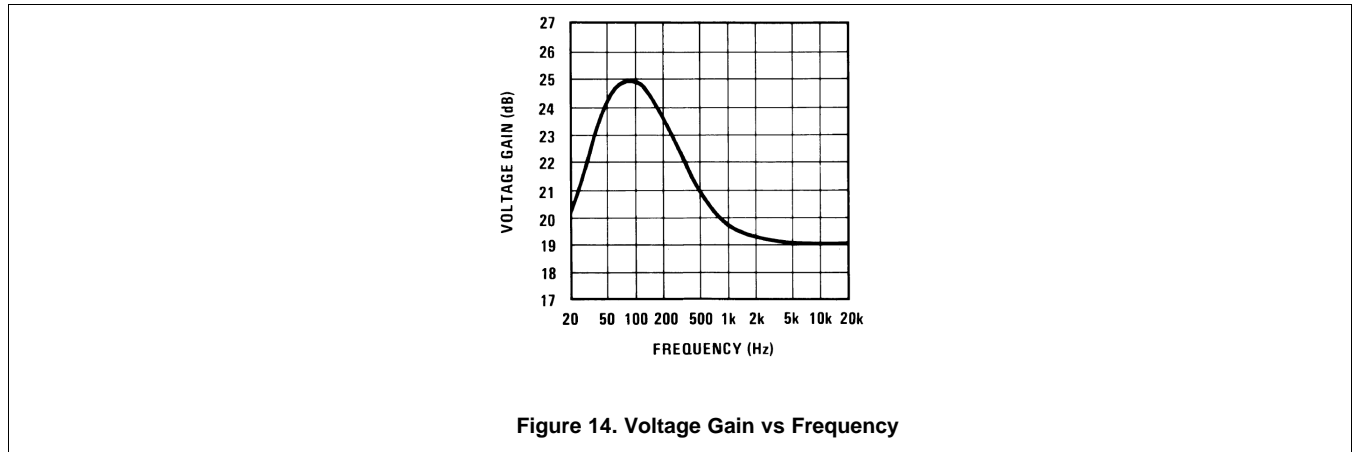

9.2.3 LM386 with Gain = 50

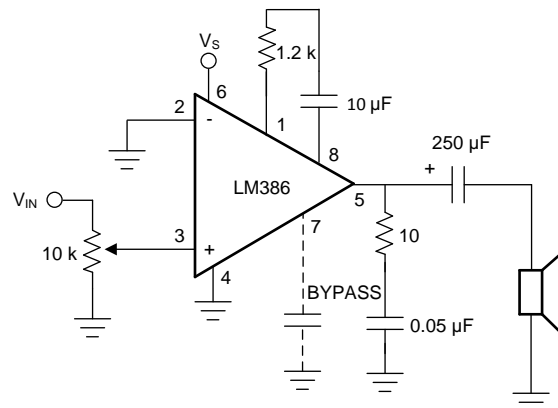

Copyright © 2017, Texas Instruments Incorporated

Figure 15. LM386 with Gain = 200

9.2.3.1 Design Requirements

DESIGN PARAMETER	EXAMPLE VALUE
Load Impedance	4 Ω to 32 Ω
Supply Voltage	5 Ω to 12 Ω

9.2.3.2 Detailed Design Procedure

The Detailed Design Procedure can be found in the [Detailed Design Procedure](#) section.

9.2.3.3 Application Curves

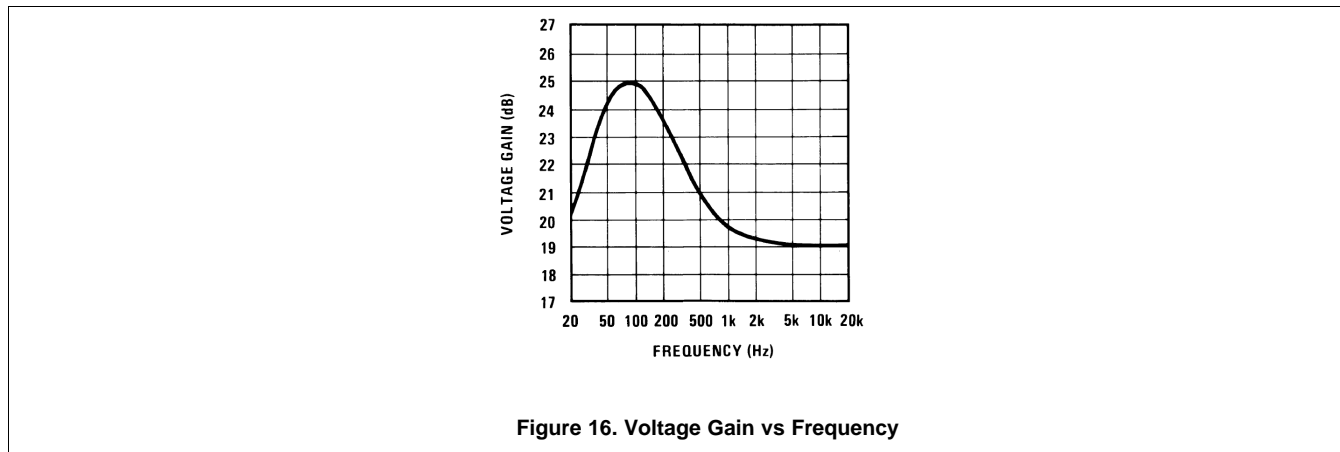

9.2.4 Low Distortion Power Wienbridge Oscillator

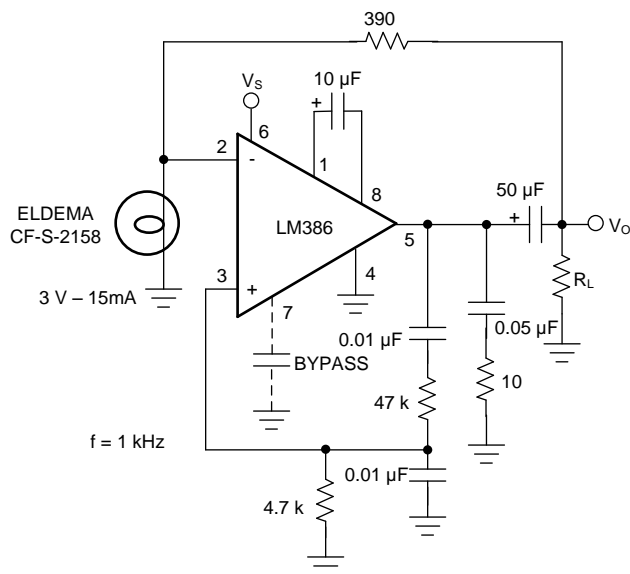

Copyright © 2017, Texas Instruments Incorporated

Figure 17. Low Distortion Power Wienbridge Oscillator

9.2.4.1 Design Requirements

DESIGN PARAMETER	EXAMPLE VALUE
Load Impedance	4 Ω to 32 Ω
Supply Voltage	5 Ω to 12 Ω

9.2.4.2 Detailed Design Procedure

The Detailed Design Procedure can be found in the [Detailed Design Procedure](#) section.

9.2.4.3 Application Curves

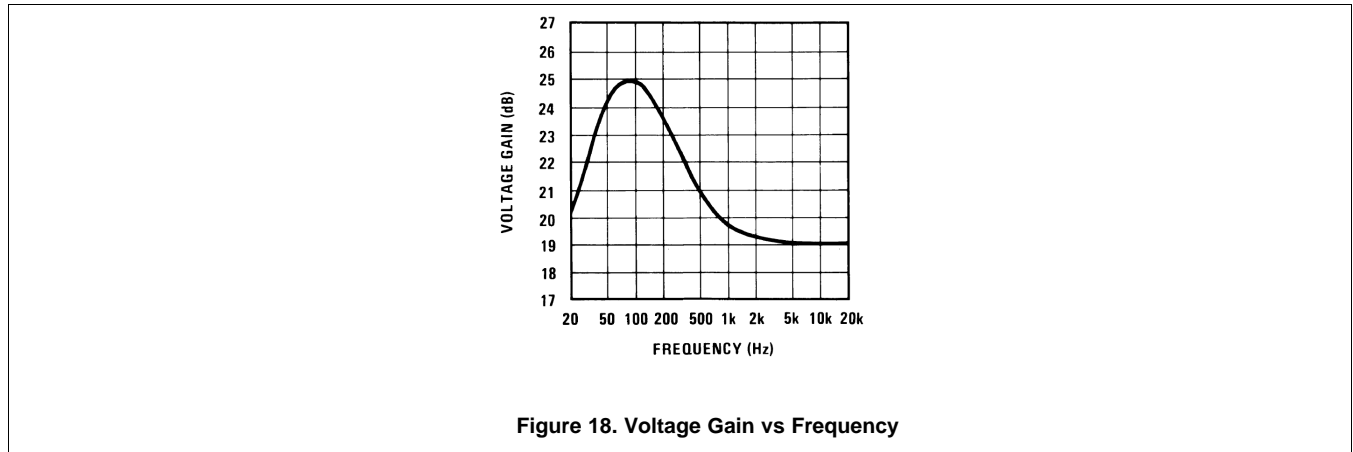

9.2.5 LM386 with Bass Boost

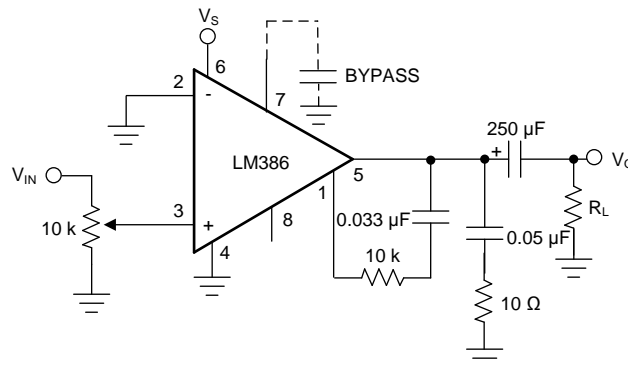

Copyright © 2017, Texas Instruments Incorporated

Figure 19. LM386 with Bass Boost

9.2.5.1 Design Requirements

DESIGN PARAMETER	EXAMPLE VALUE
Load Impedance	4 Ω to 32 Ω
Supply Voltage	5 Ω to 12 Ω

9.2.5.2 Detailed Design Procedure

The Detailed Design Procedure can be found in the [Detailed Design Procedure](#) section.

9.2.5.3 Application Curves

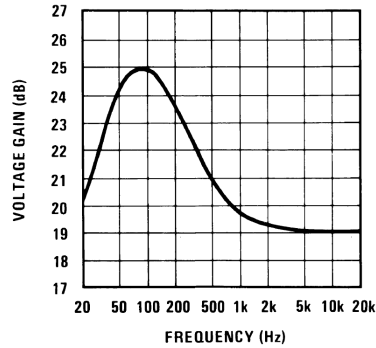
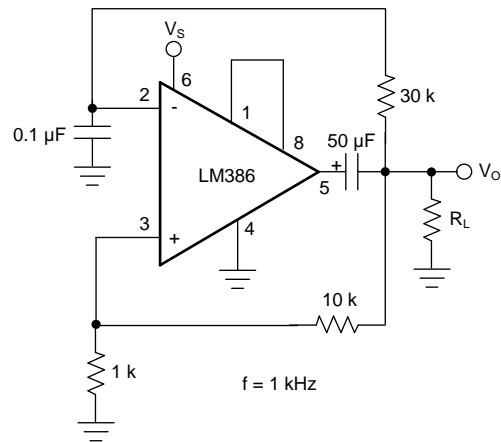

Figure 20. Voltage Gain vs Frequency

9.2.6 Square Wave Oscillator



Copyright © 2017, Texas Instruments Incorporated

Figure 21. Square Wave Oscillator

9.2.6.1 Design Requirements

DESIGN PARAMETER	EXAMPLE VALUE
Load Impedance	4 Ω to 32 Ω
Supply Voltage	5 V to 12 V

9.2.6.2 Detailed Design Procedure

The Detailed Design Procedure can be found in the [Detailed Design Procedure](#) section.

9.2.6.3 Application Curves

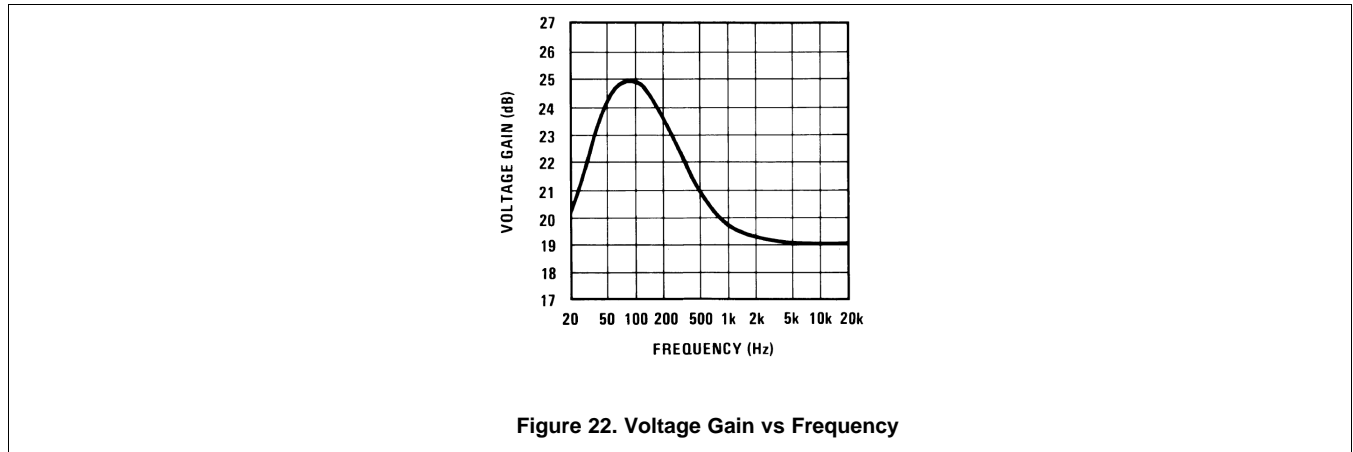

9.2.7 AM Radio Power Amplifier

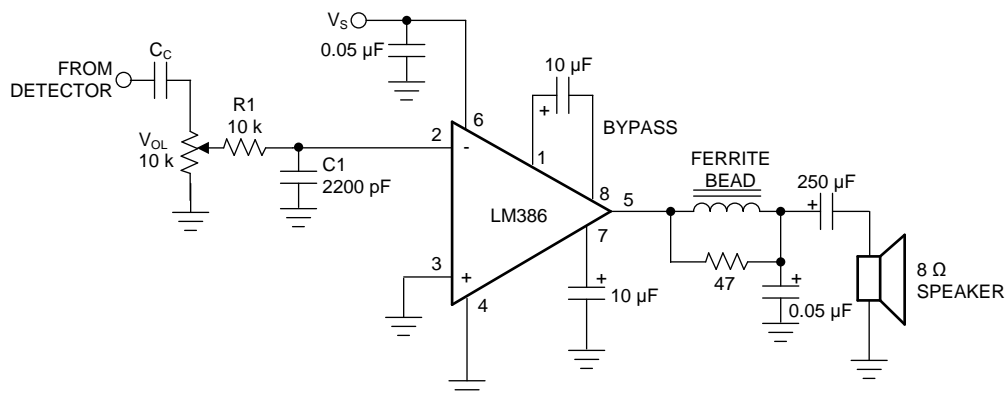

Copyright © 2017, Texas Instruments Incorporated

Figure 23. AM Radio Power Amplifier

9.2.7.1 Design Requirements

DESIGN PARAMETER	EXAMPLE VALUE
Load Impedance	4 Ω to 32 Ω
Supply Voltage	5 Ω to 12 Ω

9.2.7.2 Detailed Design Procedure

The Detailed Design Procedure can be found in the [Detailed Design Procedure](#) section.

9.2.7.3 Application Curves

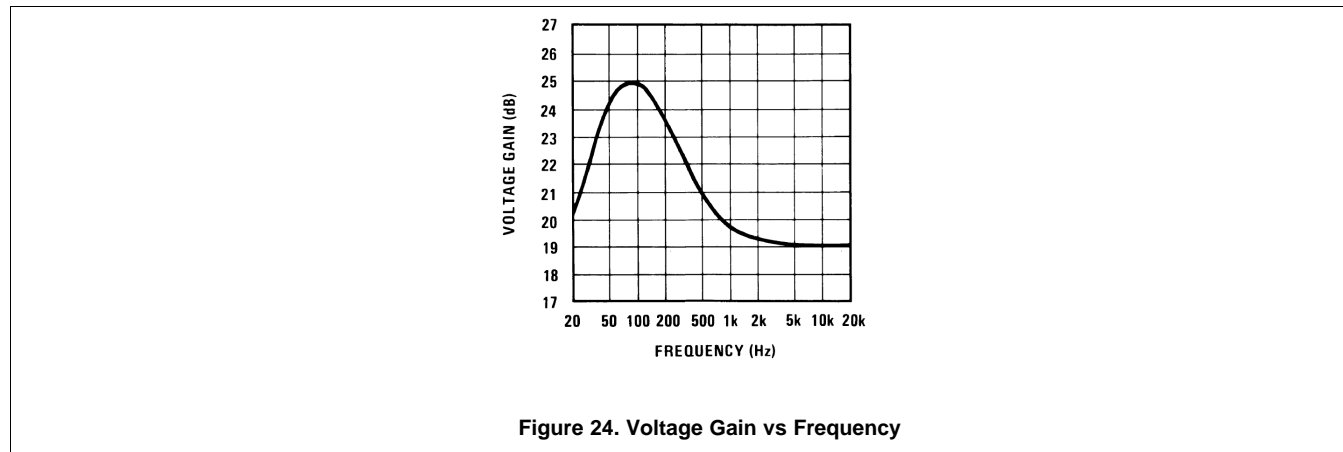

10 Power Supply Recommendations

The LM386 is specified for operation up to 12 V or 18 V. The power supply should be well regulated and the voltage must be within the specified values. It is recommended to place a capacitor to GND close to the LM386 power supply pin.

11 Layout

11.1 Layout Guidelines

Place all required components as close as possible to the device. Use short traces for the output to the speaker connection. Route the analog traces far from the digital signal traces and avoid crossing them.

11.2 Layout Examples

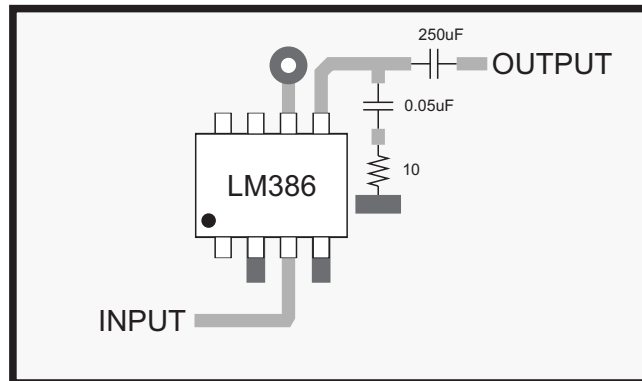

Figure 25. Layout Example for Minimum Parts Gain = 20 dB on PDIP package

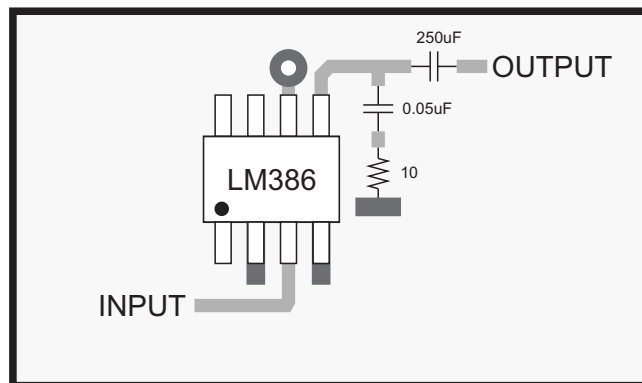
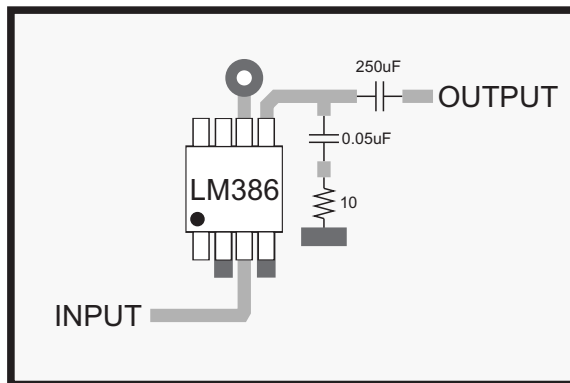

Figure 26. Layout Example for Minimum Parts Gain = 20 dB on SOIC package

Layout Examples (continued)



-  Connection to ground plane
-  Connection to power 5V
-  Top layer traces
-  Top layer ground plane

Figure 27. Layout Example for Minimum Parts Gain = 20 dB on VSSOP package

12 Device and Documentation Support

12.1 Device Support

12.1.1 Development Support

12.2 Documentation Support

12.3 Related Documentation

12.4 Related Links

The table below lists quick access links. Categories include technical documents, support and community resources, tools and software, and quick access to sample or buy.

Table 1. Related Links

PARTS	PRODUCT FOLDER	SAMPLE & BUY	TECHNICAL DOCUMENTS	TOOLS & SOFTWARE	SUPPORT & COMMUNITY
LM386M-1	Click here	Click here	Click here	Click here	Click here
LM386MX-1	Click here	Click here	Click here	Click here	Click here

12.5 Community Resources

The following links connect to TI community resources. Linked contents are provided "AS IS" by the respective contributors. They do not constitute TI specifications and do not necessarily reflect TI's views; see TI's [Terms of Use](#).

TI E2E™ Online Community *TI's Engineer-to-Engineer (E2E) Community*. Created to foster collaboration among engineers. At e2e.ti.com, you can ask questions, share knowledge, explore ideas and help solve problems with fellow engineers.

Design Support *TI's Design Support* Quickly find helpful E2E forums along with design support tools and contact information for technical support.

12.6 Trademarks

E2E is a trademark of Texas Instruments.
All other trademarks are the property of their respective owners.

12.7 Electrostatic Discharge Caution



These devices have limited built-in ESD protection. The leads should be shorted together or the device placed in conductive foam during storage or handling to prevent electrostatic damage to the MOS gates.

12.8 Glossary

SLYZ022 — *TI Glossary*.

This glossary lists and explains terms, acronyms, and definitions.

13 Mechanical, Packaging, and Orderable Information

The following pages include mechanical, packaging, and orderable information. This information is the most current data available for the designated devices. This data is subject to change without notice and revision of this document. For browser-based versions of this data sheet, refer to the left-hand navigation.

PACKAGING INFORMATION

Orderable Device	Status (1)	Package Type	Package Drawing	Pins	Package Qty	Eco Plan (2)	Lead/Ball Finish (6)	MSL Peak Temp (3)	Op Temp (°C)	Device Marking (4/5)	Samples
LM386M-1	ACTIVE	SOIC	D	8	95	TBD	Call TI	Call TI	0 to 70	LM386 M-1	Samples
LM386M-1/NOPB	ACTIVE	SOIC	D	8	95	Green (RoHS & no Sb/Br)	CU SN	Level-1-260C-UNLIM	0 to 70	LM386 M-1	Samples
LM386MMX-1/NOPB	ACTIVE	VSSOP	DGK	8	3500	Green (RoHS & no Sb/Br)	CU SN	Level-1-260C-UNLIM	0 to 70	Z86	Samples
LM386MX-1/NOPB	ACTIVE	SOIC	D	8	2500	Green (RoHS & no Sb/Br)	CU SN	Level-1-260C-UNLIM	0 to 70	LM386 M-1	Samples
LM386N-1/NOPB	ACTIVE	PDIP	P	8	40	Green (RoHS & no Sb/Br)	CU SN Call TI	Level-1-NA-UNLIM	0 to 70	LM 386N-1	Samples
LM386N-3/NOPB	ACTIVE	PDIP	P	8	40	Green (RoHS & no Sb/Br)	CU SN	Level-1-NA-UNLIM	0 to 70	LM 386N-3	Samples
LM386N-4/NOPB	ACTIVE	PDIP	P	8	40	Green (RoHS & no Sb/Br)	CU SN Call TI	Level-1-NA-UNLIM	0 to 70	LM 386N-4	Samples

(1) The marketing status values are defined as follows:

ACTIVE: Product device recommended for new designs.

LIFEBUY: TI has announced that the device will be discontinued, and a lifetime-buy period is in effect.

NRND: Not recommended for new designs. Device is in production to support existing customers, but TI does not recommend using this part in a new design.

PREVIEW: Device has been announced but is not in production. Samples may or may not be available.

OBSOLETE: TI has discontinued the production of the device.

(2) Eco Plan - The planned eco-friendly classification: Pb-Free (RoHS), Pb-Free (RoHS Exempt), or Green (RoHS & no Sb/Br) - please check <http://www.ti.com/productcontent> for the latest availability information and additional product content details.

TBD: The Pb-Free/Green conversion plan has not been defined.

Pb-Free (RoHS): TI's terms "Lead-Free" or "Pb-Free" mean semiconductor products that are compatible with the current RoHS requirements for all 6 substances, including the requirement that lead not exceed 0.1% by weight in homogeneous materials. Where designed to be soldered at high temperatures, TI Pb-Free products are suitable for use in specified lead-free processes.

Pb-Free (RoHS Exempt): This component has a RoHS exemption for either 1) lead-based flip-chip solder bumps used between the die and package, or 2) lead-based die adhesive used between the die and leadframe. The component is otherwise considered Pb-Free (RoHS compatible) as defined above.

Green (RoHS & no Sb/Br): TI defines "Green" to mean Pb-Free (RoHS compatible), and free of Bromine (Br) and Antimony (Sb) based flame retardants (Br or Sb do not exceed 0.1% by weight in homogeneous material)

(3) MSL, Peak Temp. - The Moisture Sensitivity Level rating according to the JEDEC industry standard classifications, and peak solder temperature.

(4) There may be additional marking, which relates to the logo, the lot trace code information, or the environmental category on the device.

⁽⁵⁾ Multiple Device Markings will be inside parentheses. Only one Device Marking contained in parentheses and separated by a "-" will appear on a device. If a line is indented then it is a continuation of the previous line and the two combined represent the entire Device Marking for that device.

⁽⁶⁾ Lead/Ball Finish - Orderable Devices may have multiple material finish options. Finish options are separated by a vertical ruled line. Lead/Ball Finish values may wrap to two lines if the finish value exceeds the maximum column width.

Important Information and Disclaimer:The information provided on this page represents TI's knowledge and belief as of the date that it is provided. TI bases its knowledge and belief on information provided by third parties, and makes no representation or warranty as to the accuracy of such information. Efforts are underway to better integrate information from third parties. TI has taken and continues to take reasonable steps to provide representative and accurate information but may not have conducted destructive testing or chemical analysis on incoming materials and chemicals. TI and TI suppliers consider certain information to be proprietary, and thus CAS numbers and other limited information may not be available for release.

In no event shall TI's liability arising out of such information exceed the total purchase price of the TI part(s) at issue in this document sold by TI to Customer on an annual basis.

TAPE AND REEL INFORMATION



QUADRANT ASSIGNMENTS FOR PIN 1 ORIENTATION IN TAPE



*All dimensions are nominal

Device	Package Type	Package Drawing	Pins	SPQ	Reel Diameter (mm)	Reel Width W1 (mm)	A0 (mm)	B0 (mm)	K0 (mm)	P1 (mm)	W (mm)	Pin1 Quadrant
LM386MMX-1/NOPB	VSSOP	DGK	8	3500	330.0	12.4	5.3	3.4	1.4	8.0	12.0	Q1
LM386MX-1/NOPB	SOIC	D	8	2500	330.0	12.4	6.5	5.4	2.0	8.0	12.0	Q1

TAPE AND REEL BOX DIMENSIONS

*All dimensions are nominal

Device	Package Type	Package Drawing	Pins	SPQ	Length (mm)	Width (mm)	Height (mm)
LM386MMX-1/NOPB	VSSOP	DGK	8	3500	367.0	367.0	35.0
LM386MX-1/NOPB	SOIC	D	8	2500	367.0	367.0	35.0

D (R-PDSO-G8)

PLASTIC SMALL OUTLINE



- NOTES:
- A. All linear dimensions are in inches (millimeters).
 - B. This drawing is subject to change without notice.
 - C. Body length does not include mold flash, protrusions, or gate burrs. Mold flash, protrusions, or gate burrs shall not exceed 0.006 (0,15) each side.
 - D. Body width does not include interlead flash. Interlead flash shall not exceed 0.017 (0,43) each side.
 - E. Reference JEDEC MS-012 variation AA.

P (R-PDIP-T8)

PLASTIC DUAL-IN-LINE PACKAGE



- NOTES:
- A. All linear dimensions are in inches (millimeters).
 - B. This drawing is subject to change without notice.
 - C. Falls within JEDEC MS-001 variation BA.

DGK (S-PDSO-G8)

PLASTIC SMALL-OUTLINE PACKAGE



- NOTES:
- A. All linear dimensions are in millimeters.
 - B. This drawing is subject to change without notice.
 - C. Body length does not include mold flash, protrusions, or gate burrs. Mold flash, protrusions, or gate burrs shall not exceed 0.15 per end.
 - D. Body width does not include interlead flash. Interlead flash shall not exceed 0.50 per side.
 - E. Falls within JEDEC MO-187 variation AA, except interlead flash.



- NOTES:
- A. All linear dimensions are in millimeters.
 - B. This drawing is subject to change without notice.
 - C. Publication IPC-7351 is recommended for alternate designs.
 - D. Laser cutting apertures with trapezoidal walls and also rounding corners will offer better paste release. Customers should contact their board assembly site for stencil design recommendations. Refer to IPC-7525 for other stencil recommendations.
 - E. Customers should contact their board fabrication site for solder mask tolerances between and around signal pads.

IMPORTANT NOTICE

Texas Instruments Incorporated (TI) reserves the right to make corrections, enhancements, improvements and other changes to its semiconductor products and services per JESD46, latest issue, and to discontinue any product or service per JESD48, latest issue. Buyers should obtain the latest relevant information before placing orders and should verify that such information is current and complete.

TI's published terms of sale for semiconductor products (<http://www.ti.com/sc/docs/stdterms.htm>) apply to the sale of packaged integrated circuit products that TI has qualified and released to market. Additional terms may apply to the use or sale of other types of TI products and services.

Reproduction of significant portions of TI information in TI data sheets is permissible only if reproduction is without alteration and is accompanied by all associated warranties, conditions, limitations, and notices. TI is not responsible or liable for such reproduced documentation. Information of third parties may be subject to additional restrictions. Resale of TI products or services with statements different from or beyond the parameters stated by TI for that product or service voids all express and any implied warranties for the associated TI product or service and is an unfair and deceptive business practice. TI is not responsible or liable for any such statements.

Buyers and others who are developing systems that incorporate TI products (collectively, "Designers") understand and agree that Designers remain responsible for using their independent analysis, evaluation and judgment in designing their applications and that Designers have full and exclusive responsibility to assure the safety of Designers' applications and compliance of their applications (and of all TI products used in or for Designers' applications) with all applicable regulations, laws and other applicable requirements. Designer represents that, with respect to their applications, Designer has all the necessary expertise to create and implement safeguards that (1) anticipate dangerous consequences of failures, (2) monitor failures and their consequences, and (3) lessen the likelihood of failures that might cause harm and take appropriate actions. Designer agrees that prior to using or distributing any applications that include TI products, Designer will thoroughly test such applications and the functionality of such TI products as used in such applications.

TI's provision of technical, application or other design advice, quality characterization, reliability data or other services or information, including, but not limited to, reference designs and materials relating to evaluation modules, (collectively, "TI Resources") are intended to assist designers who are developing applications that incorporate TI products; by downloading, accessing or using TI Resources in any way, Designer (individually or, if Designer is acting on behalf of a company, Designer's company) agrees to use any particular TI Resource solely for this purpose and subject to the terms of this Notice.

TI's provision of TI Resources does not expand or otherwise alter TI's applicable published warranties or warranty disclaimers for TI products, and no additional obligations or liabilities arise from TI providing such TI Resources. TI reserves the right to make corrections, enhancements, improvements and other changes to its TI Resources. TI has not conducted any testing other than that specifically described in the published documentation for a particular TI Resource.

Designer is authorized to use, copy and modify any individual TI Resource only in connection with the development of applications that include the TI product(s) identified in such TI Resource. NO OTHER LICENSE, EXPRESS OR IMPLIED, BY ESTOPPEL OR OTHERWISE TO ANY OTHER TI INTELLECTUAL PROPERTY RIGHT, AND NO LICENSE TO ANY TECHNOLOGY OR INTELLECTUAL PROPERTY RIGHT OF TI OR ANY THIRD PARTY IS GRANTED HEREIN, including but not limited to any patent right, copyright, mask work right, or other intellectual property right relating to any combination, machine, or process in which TI products or services are used. Information regarding or referencing third-party products or services does not constitute a license to use such products or services, or a warranty or endorsement thereof. Use of TI Resources may require a license from a third party under the patents or other intellectual property of the third party, or a license from TI under the patents or other intellectual property of TI.

TI RESOURCES ARE PROVIDED "AS IS" AND WITH ALL FAULTS. TI DISCLAIMS ALL OTHER WARRANTIES OR REPRESENTATIONS, EXPRESS OR IMPLIED, REGARDING RESOURCES OR USE THEREOF, INCLUDING BUT NOT LIMITED TO ACCURACY OR COMPLETENESS, TITLE, ANY EPIDEMIC FAILURE WARRANTY AND ANY IMPLIED WARRANTIES OF MERCHANTABILITY, FITNESS FOR A PARTICULAR PURPOSE, AND NON-INFRINGEMENT OF ANY THIRD PARTY INTELLECTUAL PROPERTY RIGHTS. TI SHALL NOT BE LIABLE FOR AND SHALL NOT DEFEND OR INDEMNIFY DESIGNER AGAINST ANY CLAIM, INCLUDING BUT NOT LIMITED TO ANY INFRINGEMENT CLAIM THAT RELATES TO OR IS BASED ON ANY COMBINATION OF PRODUCTS EVEN IF DESCRIBED IN TI RESOURCES OR OTHERWISE. IN NO EVENT SHALL TI BE LIABLE FOR ANY ACTUAL, DIRECT, SPECIAL, COLLATERAL, INDIRECT, PUNITIVE, INCIDENTAL, CONSEQUENTIAL OR EXEMPLARY DAMAGES IN CONNECTION WITH OR ARISING OUT OF TI RESOURCES OR USE THEREOF, AND REGARDLESS OF WHETHER TI HAS BEEN ADVISED OF THE POSSIBILITY OF SUCH DAMAGES.

Unless TI has explicitly designated an individual product as meeting the requirements of a particular industry standard (e.g., ISO/TS 16949 and ISO 26262), TI is not responsible for any failure to meet such industry standard requirements.

Where TI specifically promotes products as facilitating functional safety or as compliant with industry functional safety standards, such products are intended to help enable customers to design and create their own applications that meet applicable functional safety standards and requirements. Using products in an application does not by itself establish any safety features in the application. Designers must ensure compliance with safety-related requirements and standards applicable to their applications. Designer may not use any TI products in life-critical medical equipment unless authorized officers of the parties have executed a special contract specifically governing such use. Life-critical medical equipment is medical equipment where failure of such equipment would cause serious bodily injury or death (e.g., life support, pacemakers, defibrillators, heart pumps, neurostimulators, and implantables). Such equipment includes, without limitation, all medical devices identified by the U.S. Food and Drug Administration as Class III devices and equivalent classifications outside the U.S.

TI may expressly designate certain products as completing a particular qualification (e.g., Q100, Military Grade, or Enhanced Product). Designers agree that it has the necessary expertise to select the product with the appropriate qualification designation for their applications and that proper product selection is at Designers' own risk. Designers are solely responsible for compliance with all legal and regulatory requirements in connection with such selection.

Designer will fully indemnify TI and its representatives against any damages, costs, losses, and/or liabilities arising out of Designer's non-compliance with the terms and provisions of this Notice.