

KEY-301 / KEY-302 / KEY-304

Keyring 27MHz Remote Control Transmitter

Features

- Small keyring transmitters to replace the FMT-301, FMT-302 and FMT-304
- Flashing LED indicates flat battery
- Crystal based architecture, providing faster frequency settling, greater modulation depth and reduced temperature dependence
- Available with customised front label, brand it with your own company logo
- Easy to program and install with code switch technology
- Durable plastic case
- Available with 1, 2, and 4 channels

Description

Operates in the 27MHz band, the KEY series achieves the highest possible standard of performance by using a crystal-controlled, frequency modulated (FM) radio signal. The onboard microcontroller uses the latest technology allowing for easy setup and installation while providing maximum security and reliability.

The KEY ring transmitter uses a LED light to indicate a flat battery status. The 1Hz flashing of the LED indicates a flat battery. The blue LED light will be "on" when the transmitter is activated by simply pressing the button on the front.

The KEY ring transmitter uses a high capacity (150mAh) 6 volt battery instead of the usual low capacity (30mAh) 12 volt remote control battery. This allows the user to use longer lasting batteries for more reliable operation.

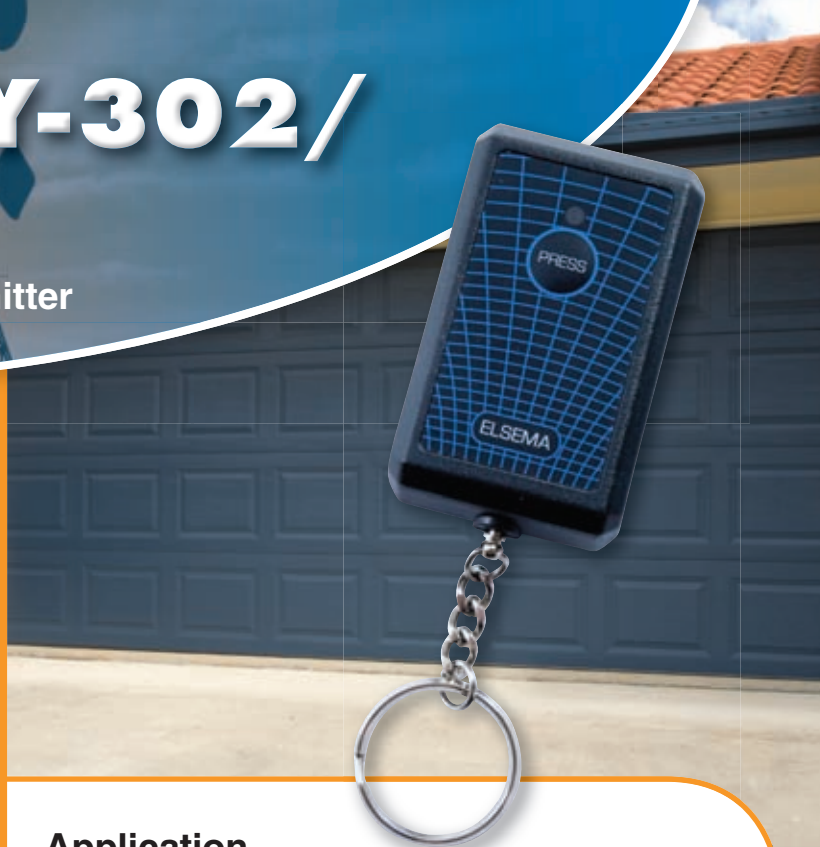

Application

- A remote control switching device for various uses eg. Garage doors, lights, gates, or automatic telephone dialers.
- A personal security alarm activator for home safety or cash carrying businesses eg. Banks, shops, service stations, etc.
- A calling device for the elderly or handicapped.

Operating Distance

Range (metres)	Receiver Antenna	Receiver Type
Up to 50	300mm wire	FMR-... series
Up to 100	Elsema's ANT27M	FMR-... series

(Range tests were done in an open area test site with line-of-sight operation and no interference. The receiver antenna wire was fixed vertically, away from any metal objects.)

Compatibility

All Elsema type FMR-... series Receivers

Products in the Range

KEY-301
1-channel



KEY-302
2-channel

KEY-304
4-channel



KEY-301NL*
1-channel

KEY-302NL*
2-channel

KEY-304NL*
4-channel

* NL is No Label, allowing you to brand it with your own company logo on the front label. For customised labels see page with detailed dimensions and contact details of Elsema's label manufacturer.

Other compatible batteries are:

- Duracell 28L (170mAh)
- Kodak K28L (160mAh)
- Energizer A544 (150mAh) or
- Sanyo 2CR-1/3N (160mAh).

Accessories

(Also available separately)



Key ring



4LR44
6V BATTERY
150mAh

Technical Data

Power Source	6V Alkaline Battery (4LR44) Also known as 4SR44, A544, PX28L, K28L, 28L or 2CR-1/3N
Current Consumption	40mA (typical) at 6VDC supply during transmission
Standby Current	Less than 6 uA
Operating Frequency	27.145MHz (Other frequency available: 27.045, 27.195 & 27.455MHz. NB. 27.455 frequency is not available for Australia, Export Only)
Carrier Freq. Tolerance	Crystal controlled 30 parts per million (0-50°C)
Radiated Field Strength	70 dBuV/m at 3 metres (+-3dB) or 3uWatts
Antenna	Built-in 30mm proprietary DILEC rod
Type of Emission	Narrow-bandwidth Frequency Modulation (5K00F1D)
Bits per second	926 bps
Necessary Bandwidth	+/- 2.5 KHz
Digital Coding System	Onboard 12-way coding switch (4096 codes) (KEY-304 & KEY-302: 10-way)
Dimension	65 x 40 x 15 mm
Weight	30g (excluding battery)
Useable Operating Range	Up to 100 metres depending on building structure and receiver antenna
Compatible Receivers	All Elsema type FMR series

Block Diagram

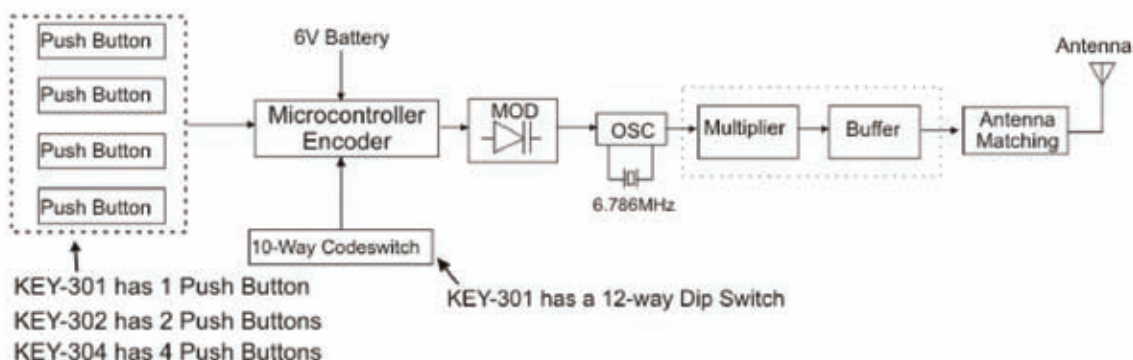

Labels

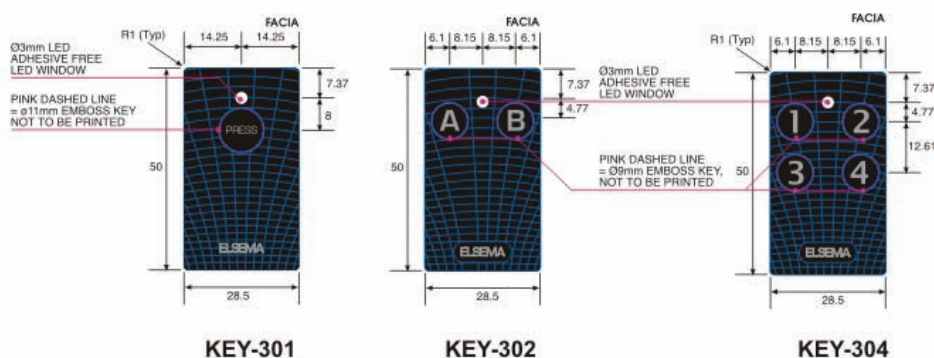

Customised front labels can be made by:

Entech Electronics Pty Ltd
37 Belford Avenue, Devon Park,
South Australia 5008, Australia

P: (61) 8 8245 6789

F: (61) 8 8245 6788

E: sales@ecg.entechgroup.net

Using KEY-302 and KEY-304

To use KEY-302 with a 2 channel receiver, and KEY-304 with a 4 channel receiver, just match the 10-way DIP switch on the transmitter to the receiver.

Using 2 Different Receivers with KEY-302

KEY-302 can also be used with 2 different single channel receivers e.g. FMR-212. Corresponding to the 12 DIP switches on the receiver:

When **Button A** is pressed, Switch 11 is transmitted as **'ON'** (Dip switch 11 on the Receiver is up)

When **Button B** is pressed, Switch 11 is transmitted as **'OFF'** (Dip switch 11 on the Receiver is down)

When **wire link** is connected (Factory default), switch 12 is **'ON'** (Dip switch 12 on the Receiver is up)

When **wire link** is disconnected (cut), switch 12 is **'OFF'** (Dip switch 12 on the Receiver is down).

(see picture below for the location of the wire link)

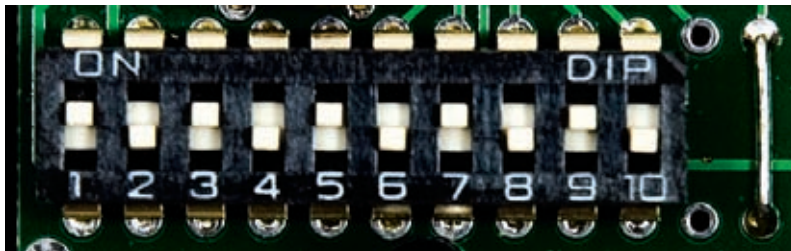

← **Wirelink**

Make sure the first 10 DIP switches on the transmitter board matches the first 10 DIP switches on the receiver. Set the receivers dip switch 11 and 12 as described above.

Using 4 Different Receivers with KEY-304

KEY-304 can also be used with 4 different single channel receivers e.g. FMR-212. This can be setup as follows:

1. Make sure the 10 DIP switches of the transmitter board matches the first 10 DIP switches of the receiver.
2. The receivers dip switch 11 and 12 configuration is illustrated below:

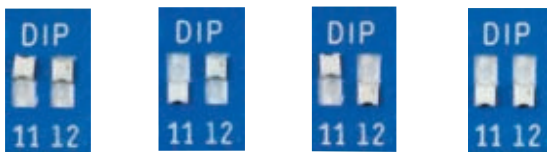

1

2

3

4

Distributed by